

O PERATION MANUAL

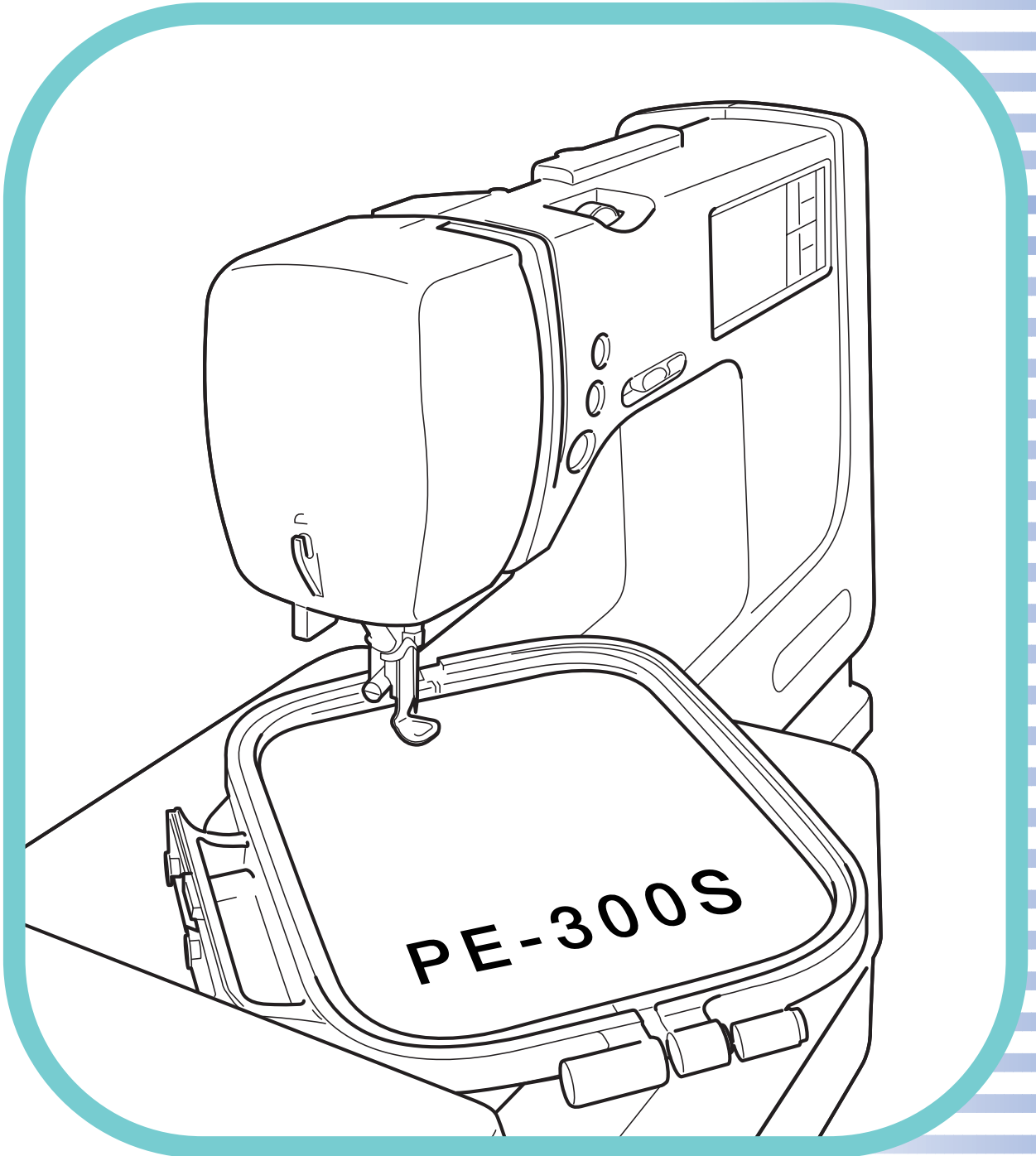

brother®

“IMPORTANT SAFETY INSTRUCTIONS”

When using a sewing machine, basic safety precautions should always be taken, including the following:
“Read all instructions before using.”

DANGER — To reduce the risk of electric shock.

1. The sewing machine should never be left unattended while plugged in. Always unplug the sewing machine from the electrical outlet immediately after using and before cleaning.
2. Always unplug before changing the light bulb. Replace bulb with same type rated 8V 2.4 watts.

WARNING — To reduce the risk of burns, fire, electric shock, or injury to persons.

1. Do not allow this sewing machine to be used as a toy. Close attention is necessary when the sewing machine is used by or near children.
2. Use this sewing machine only for its intended use as described in this manual. Use only accessories recommended by the manufacturer as contained in this manual.
3. Never operate this sewing machine if it has a damaged cord or plug, if it is not working properly, if it has been dropped or damaged, or dropped into water. Return the sewing machine to the nearest authorized dealer or service center for examination, repair, electrical or mechanical adjustment.
4. Never operate the sewing machine with any air openings blocked. Keep ventilation openings of the sewing machine and foot control free from the accumulation of lint, dust, and loose cloth.
5. Never drop or insert any object into any opening.
6. Do not use outdoors.
7. Do not operate where aerosol (spray) products are being used or where oxygen is being administered.
8. To disconnect, turn the main switch to the symbol “O” position which represents off, then remove plug from outlet.
9. Do not unplug by pulling on cord. To unplug, grasp the plug, not the cord.
10. Keep fingers away from all moving parts. Special care is required around the sewing machine needle.
11. Always use the proper needle plate. The wrong plate can cause the needle to break.
12. Do not use bent needles.
13. Do not pull or push fabric while stitching. It may deflect the needle causing it to break.
14. Switch the sewing machine to the symbol “O” position when making any adjustments in the needle area, such as threading needle, changing needle, threading bobbin, or changing presser foot, and the like.
15. Always unplug the sewing machine from the electrical outlet when removing covers, lubricating, or when making any other user servicing adjustments mentioned in the instruction manual.
16. This sewing machine is not intended for use by young children or infirm persons without supervision.
17. Young children should be supervised to ensure that they do not play with this sewing machine.

“SAVE THESE INSTRUCTIONS”
“This sewing machine is intended for household use.”

FOR USERS IN THE UK, EIRE, MALTA AND CYPRUS ONLY.

If your sewing machine is fitted with a three-pin non-rewireable BS plug then please read the following.

IMPORTANT

If the available socket outlet is not suitable for the plug supplied with this equipment, it should be cut off and an appropriate three-pin plug fitted. With alternative plugs an approved fuse must be fitted in the plug.

NOTE

The plug served from the main lead must be destroyed as a plug with bared flexible cords is hazardous if engaged in a live socket outlet. In the event of replacing the plug fuse, use a fuse approved by ASTA to BS 1362, i.e. carrying the  mark, rating as marked on plug.

Always replace the fuse cover, never use plugs with the fuse cover omitted.

WARNING

DO NOT CONNECT EITHER WIRE TO THE EARTH TERMINAL WHICH IS MARKED WITH THE LETTER 'E', BY THE EARTH SYMBOL  OR COLOURED GREEN OR YELLOW.

The wires in this main lead are coloured in accordance with the following code:

Blue Neutral

Brown Live

As the colours of the wiring in the main lead of this appliance may not correspond with the coloured markings identifying the terminals in your plug, proceed as follows.

The wire which is coloured blue must be connected to the terminal which is marked with the letter 'N' or coloured black or blue.

The wire which is coloured brown must be connected to the terminal which is marked with the letter 'L' or coloured red or brown.

CONGRATULATIONS ON CHOOSING A BROTHER COMPUTER SEWING MACHINE

Your machine is the most advanced computerized home use sewing machine available. To fully enjoy all the features incorporated into it, we suggest that you study this booklet.

PLEASE READ BEFORE USING YOUR SEWING MACHINE

For safe operation

1. Be sure to keep your eye on the needle while sewing. Do not touch the balance wheel, thread take-up, needle, or other moving parts.
2. Remember to turn off the power switch and unplug the cord when:
 - Operation is completed
 - Replacing or removing the needle or any other parts
 - A power failure occurs during use
 - Maintaining the machine
 - Leaving the machine unattended
3. Do not store anything on the foot controller.
4. Plug the machine directly into the wall. Do not use extension cords.

For a longer service life

1. When storing your sewing machine, avoid direct sunlight and high humidity locations. Do not store the sewing machine beside a space heater, iron, or other hot objects.
2. Use only neutral soaps or detergents to clean the case. Benzene, thinner, and scouring powders can damage the case and machine, and should never be used.
3. Do not drop or hit the machine.
4. Always consult the operation manual when replacing or installing any accessories, the presser feet, needle, or other parts to assure correct installation.

For repair or adjustment

In the event that a malfunction occurs or adjustment is required, first follow the troubleshooting table in the back of the operation manual to inspect and adjust the machine yourself. If the problem persists, please consult your nearest authorized Brother service center.

WARNING LABELS

There should be several warning labels on your sewing machine.
Please heed warning labels when operating the sewing machine.
If you don't understand the warnings, please contact the place of purchase.

CAUTION

Always remove the embroidery unit before moving the sewing machine. Otherwise the embroidery unit could fall and cause bodily injury or damage to the unit.

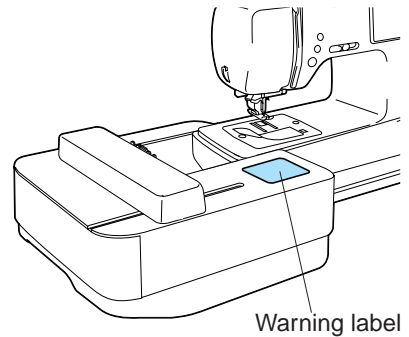

CAUTION

Always carry the embroidery unit by the handle as illustrated in Fig. 1. Do not carry it by the sides as shown in Fig. 2 or the unit may fall out from under the cover and cause bodily injury or damage to the unit.

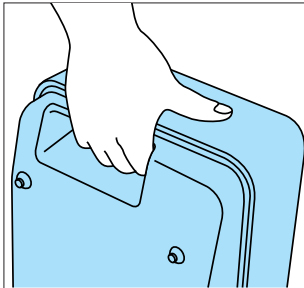

Fig. 1

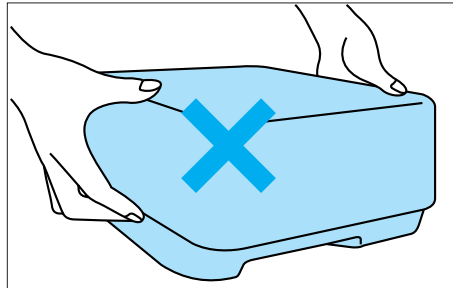
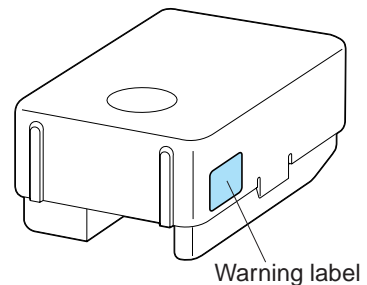
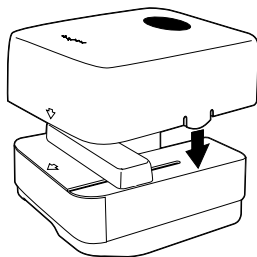

Fig. 2

- When putting the embroidery unit cover onto the unit, place it so that the arrow is on the side of the carrying handle.



CONTENTS

SETTING UP

.....	5
PRINCIPAL PARTS	5
OTHER INCLUDED ACCESSORIES	7
OPTIONS	8
SELECTION KEYS	9
Screen messages guide you through each operation	9
OPERATION BUTTONS	10
Using the operation buttons	10

BASIC SEWING MACHINE OPERATION

.....	11
FLAT BED EXTENSION TABLE	11
Free arm	11
POWER SUPPLY	12
USING THE SCREEN KEYS	13
ABOUT THE SCREEN	13
ADJUSTING THE BRIGHTNESS OF THE SCREEN	13
HOW TO CHANGE LANGUAGE	14
How to clear the language selection	15
BOBBIN WINDING / BOBBIN THREAD SETTING	16
Setting the bobbin	19
UPPER THREADING	20
STARTING AND STOPPING SEWING	23
"START/STOP" button	23
Foot controller	23
STITCH SELECTION (UTILITY STITCHES)	24
Stitches	24
TRIAL SEWING	25
STITCH WIDTH AND STITCH LENGTH	27
Adjusting the stitch width	27
Adjusting the stitch length	27
Quick adjustment reference chart for stitch width and stitch length	28
THREAD TENSION	30
Correct tension	30
Tightening the upper thread tension	30
Loosening the upper thread tension	30
PRESSER FOOT	31
Changing the presser foot	31
Changing the Embroidery foot and the zipper foot	32
FEED DOGS	33
NEEDLE	34
Checking the needle	34
Installing the needle securely	34
FABRIC/THREAD/NEEDLE COMBINATION CHART	35

UTILITY STITCHES

.....	36
STRAIGHT STITCHES	36
Changing needle position	37
Sewing corners	37
Sewing curves	38
Sewing thick seams	38
Sewing thick fabric	38
Sewing thin fabric	39
Using the free arm	39
STRETCH STITCH AND TRIPLE STITCH	40
Stretch stitch	40

Triple stitch	40
ZIGZAG STITCHES	41
Overcasting (using a zigzag stitch)	41
Applique (using a zigzag stitch)	41
Patchwork (for crazy quilt)	42
Sewing a curve with a zigzag stitch	42
DOTTED ZIGZAG	43
Attaching elastic bands	43
Overcasting	43
OVERCASTING	44
Overcasting	44
Overcasting	44
Overcasting	45
Overcasting	45
BLIND HEM STITCHES	46
If the needle does not catch the fold of hem enough	47
If the needle catches the fold of hem too much	47
BUTTONHOLE STITCHES	48
Order of one cycle	49
Sewing stretch fabrics ()	50
Buttons that do not fit into the guide plate (Odd-shaped buttons)	50
BAR TACKING	51
Thick fabrics	52
APPLIQUES	53
Sewing the applique around corners	53
SCALLOP	54
PATCHWORK STITCH	55
ZIPPER INSERTION (CENTERED AND SIDE APPLICATION)	56
Centered application	56
Side application	57
SMOCKING	59
BUTTON SEWING	60
Attaching buttons with four holes	61

EMBROIDERING

.....	62
BEFORE YOU BEGIN	62
1. Embroidery unit and memory cards (optional)	62
2. Attaching the embroidery foot "Q"	62
3. Attaching the embroidery unit	63
REMOVING EMBROIDERY UNIT	64
CHOOSING EMBROIDERY PATTERNS (PART I)	65
One-point patterns	66
Borders	68
Lettering	69
Numerals and punctuation	70
Lower and upper case letters	70
Selecting patterns from a memory card	71
CHOOSING EMBROIDERY PATTERNS (PART II)	72
If you accidentally choose the wrong design ...	72
If you choose the wrong character	72
To change size	72
To make words	73
EMBROIDERING	74
Embroidering attractive finishes	74
Setting the fabric into the embroidery frame ...	75
Fitting the embroidery frame to the embroidery unit	77
Removing the embroidery frame	77
Embroidering	78
THREAD TENSION	80

CHECKING THREAD COLORS AND TIME REQUIRED	81
Checking thread colors	81
Checking time required to complete a pattern	82
CHOOSING EMBROIDERY PLACEMENT	83
Moving the embroidery location	84
Checking the embroidering area	84
Embroidering from a specific starting point ..	85
ROTATING AND MIRRORING PATTERNS	86
Rotating patterns	86
Mirroring patterns	86
CHANGING SIZE AND STITCH DENSITY OF CHARACTERS AND BORDERS	87
To change size	87
To change stitch density (limited to certain alphabets and borders)	88
Multi-colored lettering	88
IF THE THREAD BREAKS DURING EMBROIDERY	89
If the upper thread breaks	89
When starting over from the beginning	90
Continuing after the power shuts off	90
EMBROIDERY APPLICATIONS	91
Combining characters to form words	91
Outline Embroidery	92
Embroidering appliques (using a frame pattern)	93
Embroidering onto small pieces of fabric or onto corners	94
MEMORY	95
Saving groups of characters	95
Restoring saved designs	96

MAINTENANCE

.....	97
CLEANING	97
Cleaning the screen	97
Cleaning the sewing machine surface	97
Cleaning the shuttle	97
CHANGING THE LIGHT BULB	99

TROUBLESHOOTING

.....	100
BEFORE TAKING YOUR MACHINE IN FOR SERVICE	100
Basic sewing machine maintenance	100

ERROR MESSAGES

.....	103
Warning messages	103
Instruction messages	105
Alarms	105

SEWING CHART

.....	106
-------	-----

PATTERNS (PROGRAMMED IN MACHINE)

.....	107
Utility stitches	107
Character embroidering chart	107
Frame pattern embroidering chart	107

PATTERNS (MEMORY CARD)

.....	108
ONE POINT MARK EMBROIDERY PATTERN	108

SETTING UP

PRINCIPAL PARTS

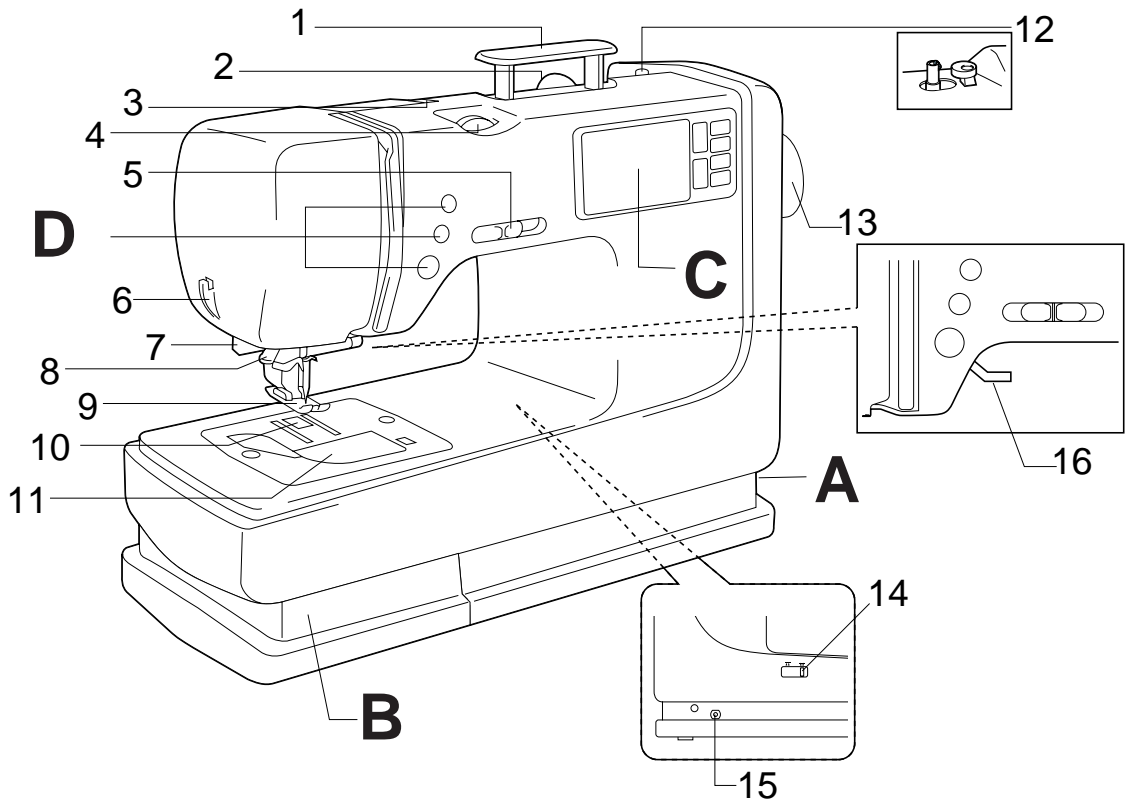

- 1- Handle
- 2- Spool cap
- 3- Thread guide for bobbin winding
- 4- Upper tension control dial
- 5- Speed range control lever
- 6- Thread cutter
- 7- Buttonhole lever
- 8- Needle threader
- 9- Presser foot
- 10- Feed dog
- 11- Bobbin cover
- 12- Bobbin winder
- 13- Balance wheel
- 14- Feed dog adjustment lever
- 15- Controller jack
- 16- Presser foot lever

- A- Main power switch and connectors
- B- Accessory compartment
- C- L.C.D. (Liquid Crystal Display)
- D- Operation buttons (Refer to page 10)

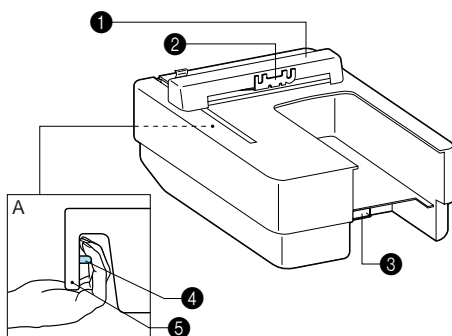

Embroidery Unit Parts

- ① Carriage
- ② Hoop holder
- ③ Connector
- A. Side view
- ④ Release button
- ⑤ Embroidery Unit Handle

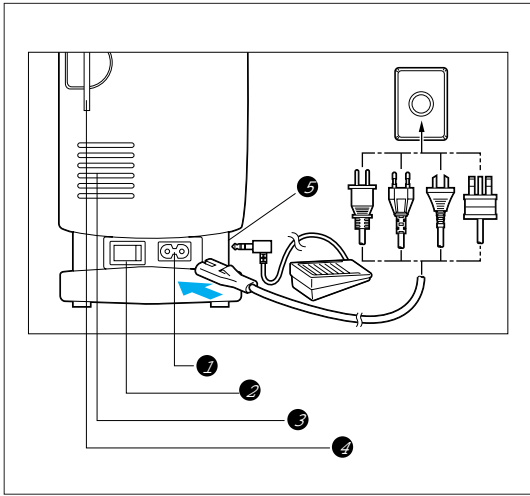

A. MAIN POWER SWITCH AND CONNECTORS

- ❶ **Power socket**
Use to connect machine to power supply.
- ❷ **Main power switch**
Use to turn on/off the main power.
- ❸ **Air vents**
- ❹ **Card slot**
Slot for memory card insertion.
- ❺ **Foot controller jack**
Use to connect the foot controller.

CAUTION

- When leaving the sewing machine unattended, the main switch of the machine must be switched off or the plug must be removed from the socket-outlet.
- When servicing the sewing machine, or when removing covers or changing bulbs, the machine or the electrical set must be unplugged.
- For U.S.A. only
This appliance has a polarized plug (one blade wider than the other). To reduce the risk of electric shock, this plug is intended to fit in a polarized outlet only one way. If the plug does not fit fully in the outlet, reverse the plug. If it still does not fit, contact a qualified electrician to install the proper outlet. Do not modify the plug in any way.

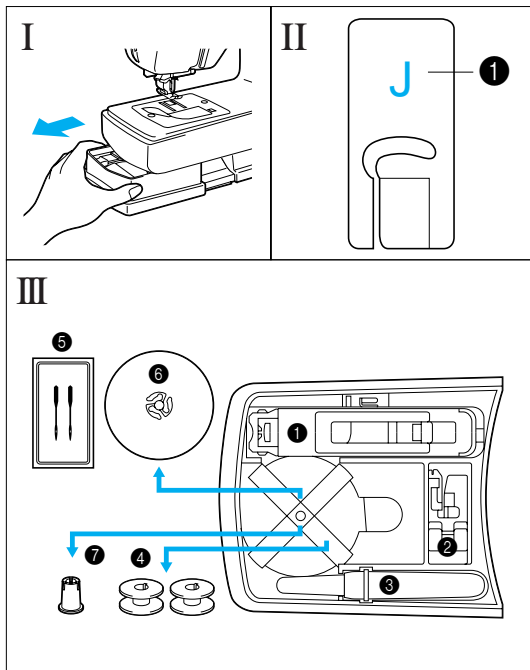

B. FLATBED ATTACHMENT WITH ACCESSORY COMPARTMENT

- I Slide accessory case to the left and out of the machine.
- II Each presser foot has a letter.
❶ Presser foot letter
- III ACCESSORY LIST
The location of each accessory is shown in figure III.

No.	Part Name	Part Code
❶	Buttonhole foot "A"	X57789-101
❷	Overcasting foot "G"	X51162-001
❸	Seam ripper	X54243-001
❹	Bobbin	X80309-001
❺	Needle set	XA6627-001
❻	Spool cap (Large)	130012-003
❼	Spool cap (Small)	XA5752-001

* Always use BROTHER accessories with this machine.

OTHER INCLUDED ACCESSORIES

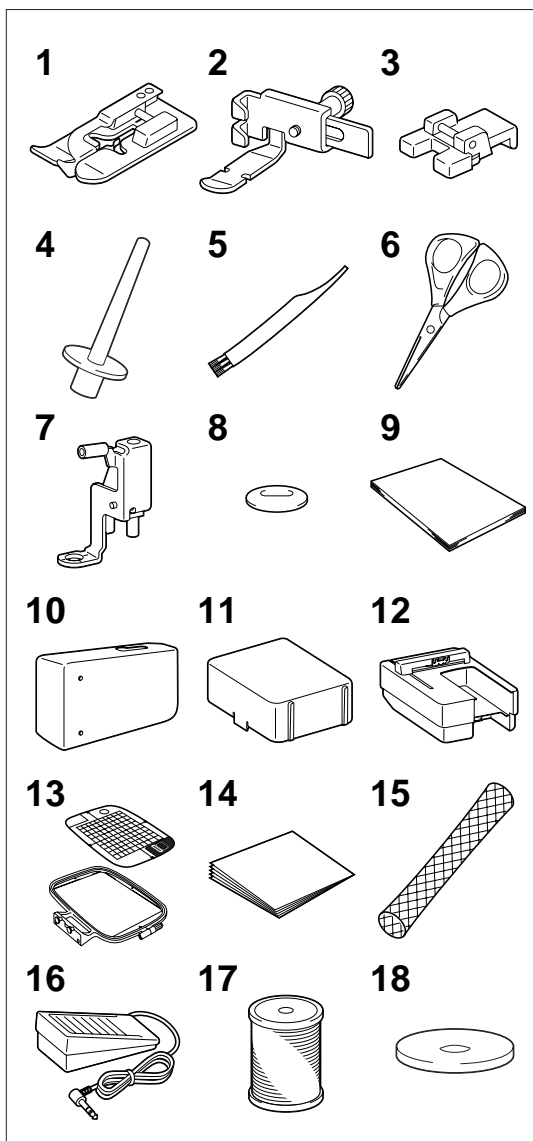

No.	Part Name	Part Code
1	Blind stitch foot "R"	X56409-001
2	Zipper foot "I"	103561-002
3	Button sew-on foot	X59375-051
4	Extra spool pin *	XA3336-051
5	Cleaning brush	XA4527-001
6	Scissors	184783-001
7	Embroidery foot "Q"	XA5357-001
8	Key	XA2005-051
9	Owner's Manual	—
10	Hard case/Extension table	—
11	Embroidery Unit Cover	—
12	Embroidery unit	—
13	Embroidery frame set (Regular)	SA432 (USA) XA6628-002 (Others)
14	Backing material (Stabilizer material)	—
15	Net **	127610-000
16	Foot controller	XA3931-051
17	Embroidery bobbin thread	SABTS (USA) X81164-001 (Others)
18	Spool felt*	X57045-001

* Extra spool pin and spool felt

Use when embroidering with metallic thread.

1. Insert the extra spool pin into the end of the bobbin winder shaft.
2. Install the spool felt and the thread spool in that order, and then thread the upper thread.

- 1 Insert the extra spool pin into the end of the bobbin winder shaft
- 2 Spool felt
- 3 Thread spool

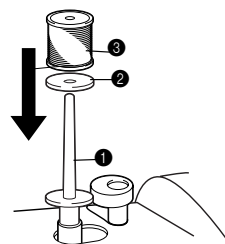

* When setting the thread spool, set it so that the thread winds off from the front of the spool.

* If using metallic thread, we recommend that you use a 90/14 home sewing machine needle.

Note

This method keeps the thread from twisting as it comes off the spool pin.

** Net

If using special threads which wind quickly off the thread spool, attach a net to the spool before using.
: Cut the net to match the size of the spool.

- 1 Net
- 2 Thread spool
- 3 Spool pin
- 4 Spool cap

If using metallic thread, we recommend that you use a 90/14 home sewing machine needle.

Note (For U.S.A. only)

Foot controller : Model N5V

This foot controller can be used for sewing machine model PE-300S.

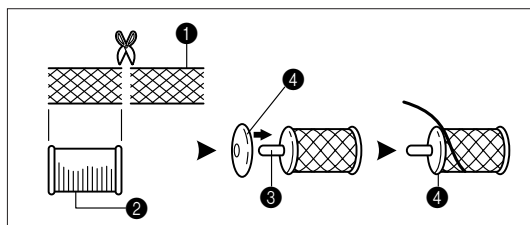

OPTIONS

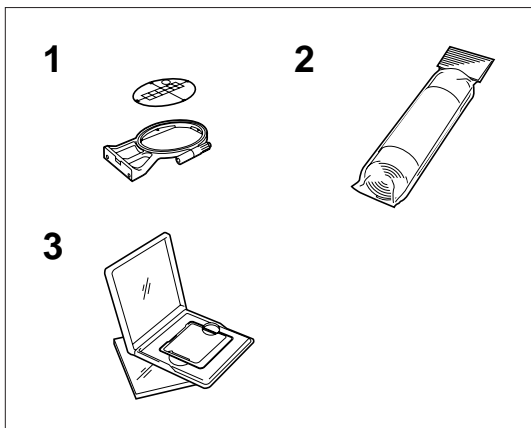

No.	Part Name	Part Code		
		U.S.A.	Others	
1	Embroidery frame set (Small)	SA431	XA6630-002	
2	Backing material (Stabilizer material)	X80914-001		
3	Memory card			
	No.1	Alphabet	SA298	X58317-001
	No.2	Flower	SA299	X58321-001
	No.6	Moskowitz's World	SA303	X58497-001
	No.7	Country Life	SA304	X59322-001
	No.8	Holiday	SA305	X59357-001
	No.9	Hobby Craft	SA306	X59511-001
	No.10	Monogram emblem	SA307	X59567-001
	No.12	Transportation	SA312	XA0275-001
	No.13	Sports Emblem	SA313	XA0517-001
	No.16	Dogs & Cats	SA316	XA1406-001
	No.20	Petite Designs	SA320	XA2869-001
	No.21	Needlework	SA321	XA2873-001
	No.25	Horse	SA325	XA3791-001
	No.27	Birds	SA327	XA4289-001
	No.28	Christmas	SA328	XA4502-001
	No.29	Lace	SA329	XA4664-001
	No.30	Wildlife Animals	SA330	XA4771-001
	No.32	Musical instrument	SA332	XA5386-001
	No.33	Trees	SA333	XA5567-001
	No.35	Cats & Dogs II	SA335	XA5629-001
No.36	Fruits & Vegetables	SA336	XA5659-001	
No.37	Applique Alphabet	SA337	XA5753-001	
No.38	Angel	SA338	XA5781-001	
No.39	Doll Face	SA339	XA5978-001	
No.40	Sports 3	SA340	XA6111-001	

WARNING





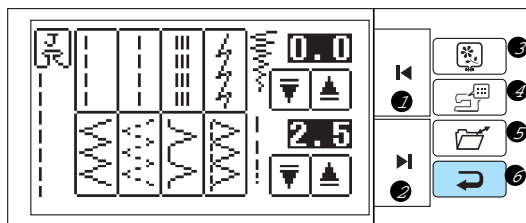

Embroidery Cards purchased overseas or non Brother brand embroidery cards may not work with your machine.

SELECTION KEYS

Screen messages guide you through each operation



SELECTION KEYS

- 1 “  ” KEY
Press while in the pattern selection screens to go back one page. (also used in Save and Restore screens)
- 2 “  ” KEY
Press to advance one screen while in pattern selection screens. (also used during Save and Restore operations)
- 3 “  ” KEY
Pushing this key will take you to the screen that will let you select pattern to embroider.
- 4 “  ” KEY
Select this when you wish to edit a selected pattern (sewing position, size, stitch density, etc...).
- 5 “  ” KEY
Use this key to save or retrieve combined letters.
- 6 “  ” KEY
Press to go back one screen of operation screens.

OPERATION BUTTONS

Using the operation buttons

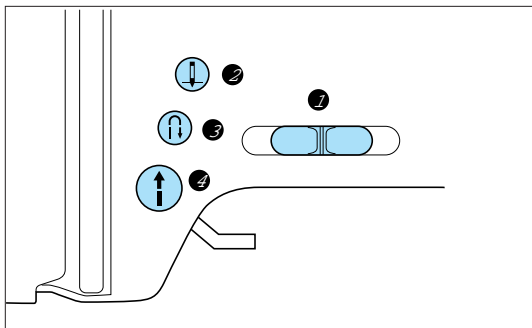

OPERATION BUTTONS

- ① **Speed range control lever**
Slide this lever to change the sewing speed.
- ② **“NEEDLE POSITION” button**
Press this button to move the needle either up or down.
- ③ **“REVERSE STITCH” button**
Hold down this button to sew either backwards or in the same place at a slow speed. When sewing a reverse stitch, sewing is done in reverse. When sewing a reinforcement stitch, three stitches are sewn at the same position.
- ④ **“START/STOP” button**
Press this button to start the machine, and then press it once more to stop the machine.
 - * Sewing continues at a slow speed while this button is pressed.
 - * The needle will stop to its highest position when the machine is stopped.

BASIC SEWING MACHINE OPERATION

FLAT BED EXTENSION TABLE

* Sewing machine cover converts to a flat bed extension table.

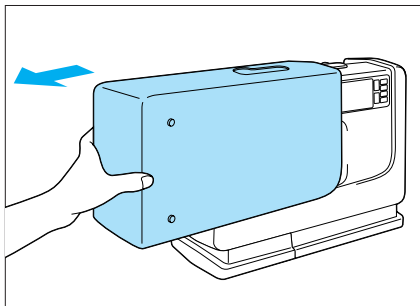

1. Slide the sewing machine cover to the left and off the machine.

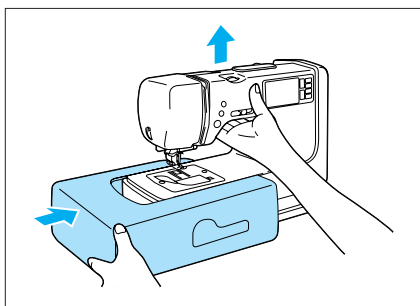

2. With the cutout section of the cover up, lift the machine a little bit and slide the cover, under the sewing machine along the grooves.

Free arm

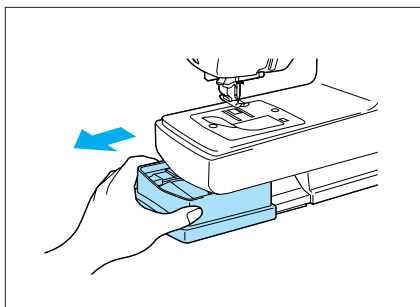

The accessory case can be removed to expose the free arm.

1. Slide accessory case to the left and out of the machine.

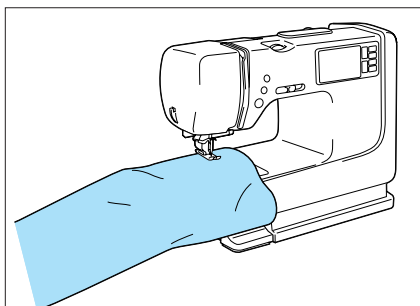

2. Convenient for sewing hard to get at tubular areas like pant legs.

POWER SUPPLY

WARNING

- When leaving the sewing machine unattended or when it is not being used, turn off the main power switch of the machine or remove the plug from the wall outlet.

CAUTION

- Do not use this sewing machine with extension cords or multi-plug adaptors, otherwise a fire or an electric shock may occur.
- Do not remove the plug from the wall outlet with wet hands, otherwise an electric shock may occur.
- When unplugging the power cord, turn off the main power switch of the machine, then grasp the plug and pull to unplug the cord. Pulling on the cord may damage it or cause a fire or an electric shock.
- Do not allow the power cord to be cut, damaged, modified, forcefully bent, pulled, twisted or bundled. In addition, do not place heavy objects on the cord or subject it to heat, otherwise the cord may be damaged or a fire or an electric shock may occur.
If the power cord or plug are damaged, contact your nearest authorized Brother dealer or service center.
- If the sewing machine is not to be used for a long period of time, unplug the power cord, otherwise a fire may occur.

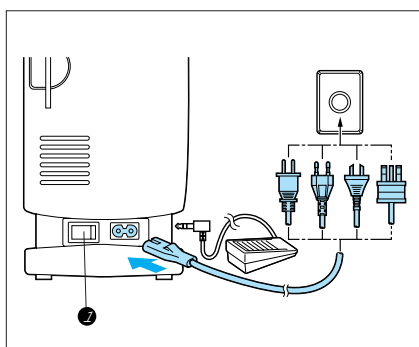

1. Insert the plug into a wall outlet.

- 1** Main power switch

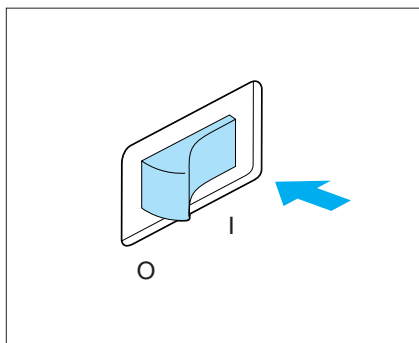

2. Set the main power switch to " I ".
3. To turn off the sewing machine, set the main power switch to " O ".

USING THE SCREEN KEYS

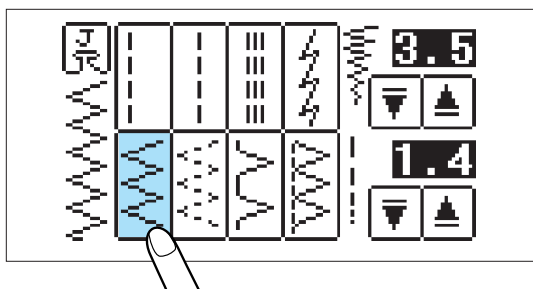

Touch a key on the screen with your finger to select the pattern which appears inside the key or to start the function or operation indicated inside the key.

CAUTION

Be sure to touch the key with your finger only. Never use a pointed instrument such as a sharp pencil or a screwdriver or a hard object to touch the key.

Furthermore, do not press down too hard on the screen, otherwise problems may result.

ABOUT THE SCREEN

NOTES

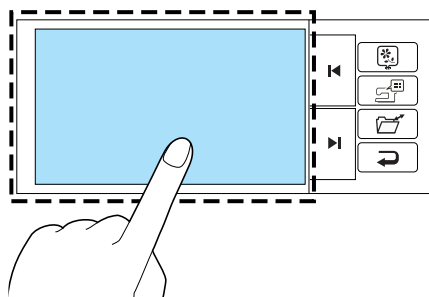

- All or parts of the screen may become darker or lighter at times because of changes in the ambient temperature around the screen. This is normal and is not the sign of a malfunction. Adjust the screen if it is difficult to read.

ADJUSTING THE BRIGHTNESS OF THE SCREEN

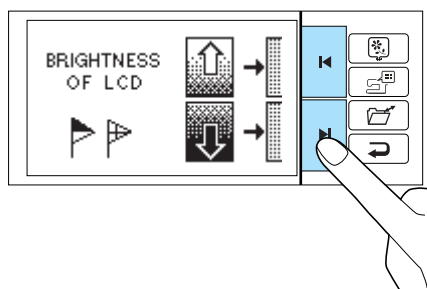

1. While touching the LCD, turn the power off and then back on again.



2. Press “” key to soften the characters on the screen, or “” key to sharpen them.
3. After you have finished adjusting, turn the power off and back on again once more.

HOW TO CHANGE LANGUAGE

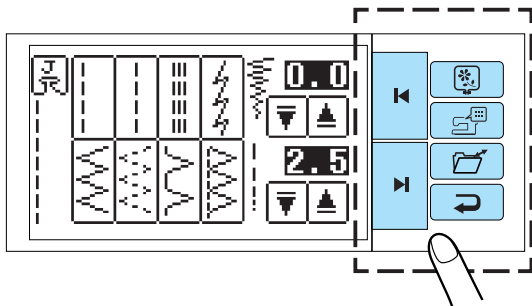

While touching a selection key, turn the power off and then back on again.

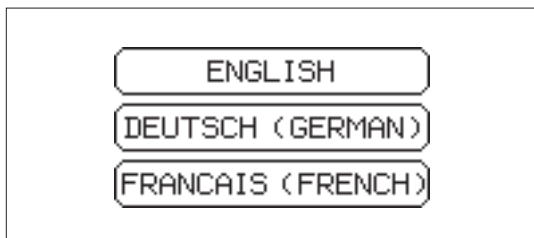

Example: To change the display language to Spanish

1. Touch the “▶” key.
2. Touch “ESPAÑOL (SPANISH)”.
This will change the language setting to Spanish.
3. The display will then return to the screen which was previously being displayed.

Note

- * When the display language is set, error messages will also be displayed in the language selected.
- * The display language can be selected from a list of 13 languages (English, German, French, Italian, Dutch, Spanish, Danish, Norwegian, Finnish, Swedish, Portuguese, Turkish and Chinese).

How to clear the language selection

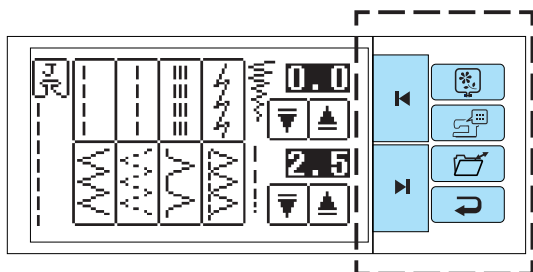

While touching a selection key, turn the power off and then back on again.



Example: To change the display language from Spanish back to English

1. Touch the "ENGLISH" key.
This will cancel the Spanish language setting.
The display will then return to the screen which was previously being displayed.

CAUTION

- This function should not be used as a translation function.
- If the power supply is turned off, the current language setting will be retained and will not be cleared.

BOBBIN WINDING / BOBBIN THREAD SETTING

Note:

Always use bobbins that are especially made for this machine. Using bobbins not designed for this machine could result in bodily injury and/or damage to the machine.

For sewing, use the plastic bobbin (X80309-001) for sewing.

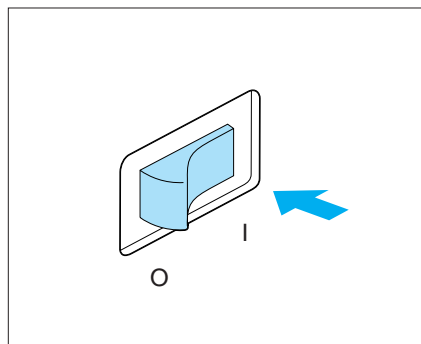
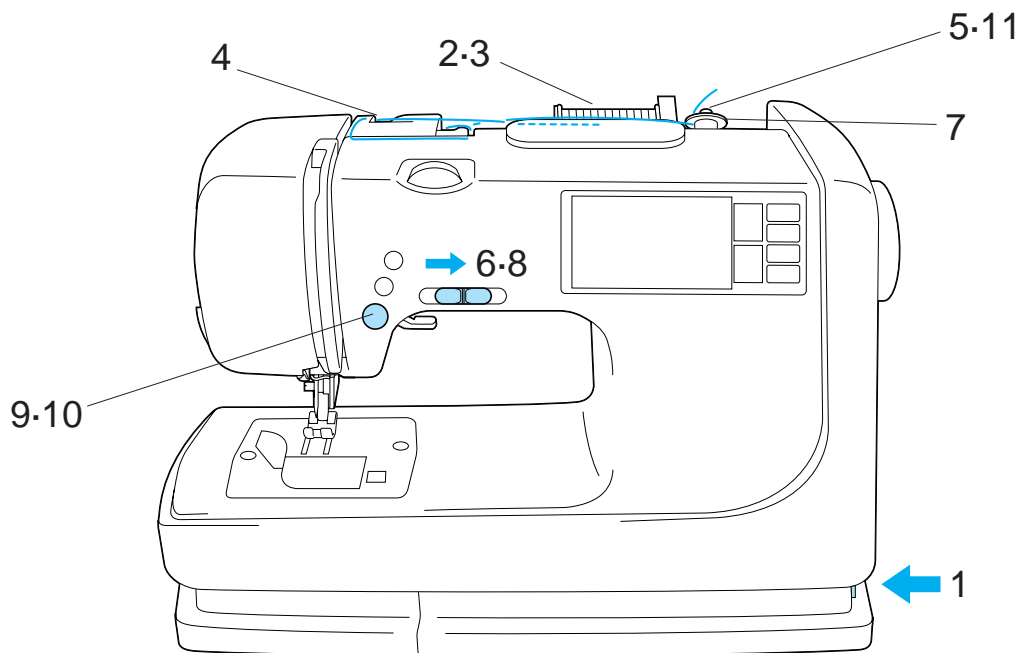

1. Turn the power on.

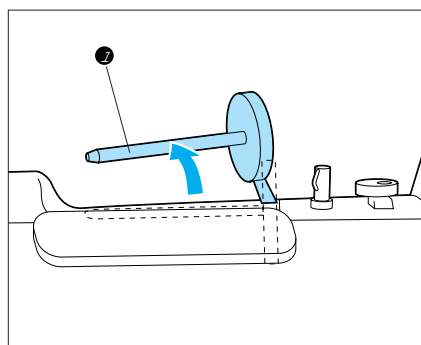

2. While winding the bobbin, be sure that the spool pin is pulled out and pushed toward the back of the sewing machine.

- ① Spool pin

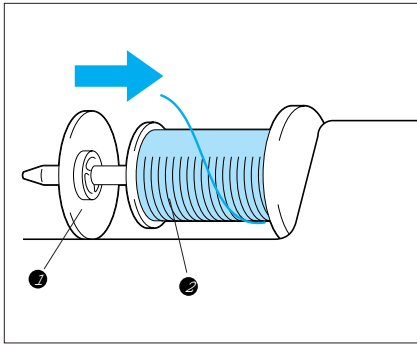

3. Set the thread spool. The thread end should come from the bottom front of the spool. The spool cap closest to the thread spool size should be used to hold the spool securely on the spool pin.

- ① Spool cap
- ② Spool

CAUTION

If the spool is placed onto the pin in the wrong direction, the thread could entwine itself around spool pin.

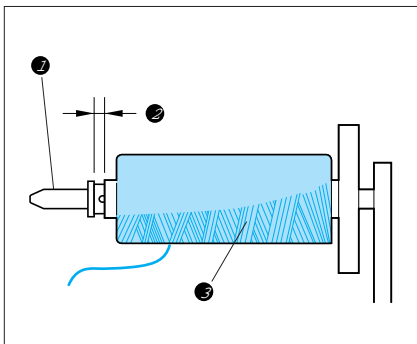

If using a fine thread such as cross wound thread, slightly separate the spool cap (small) from the thread on the spool before using.

- ① Spool cap (small)
- ② Space
- ③ Cross wound thread

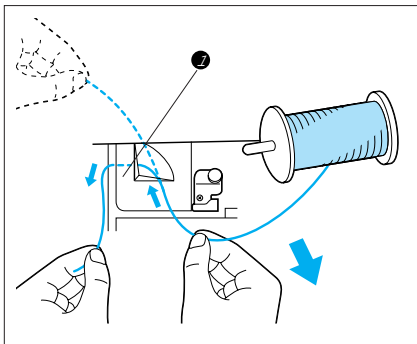

4. Pass the thread through the thread guide as shown by the arrows. Threading is easy if you hold the thread gently with your right hand while guiding the end of the thread with your left hand.

- ① Run thread all the way through the thread guides as shown.

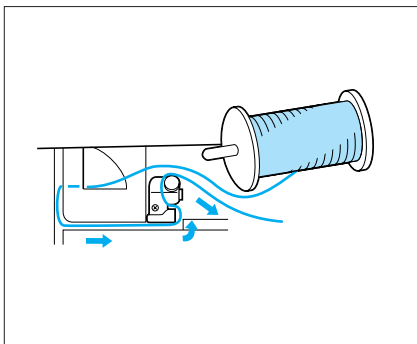

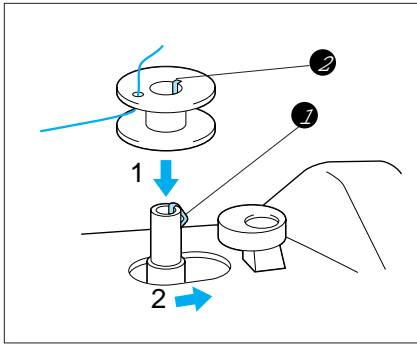

5. Guide the thread through the small hole in the side of the bobbin from the inside. Align the groove in the bobbin with the spring on the shaft and place the bobbin on the bobbin winder shaft. While holding the thread end, push the bobbin winder shaft to the right.

- ① Spring on the shaft
- ② Groove of the bobbin

6. Set the speed to minimum.

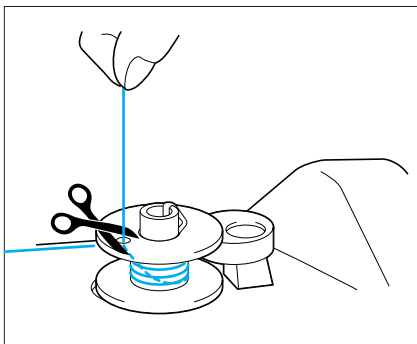

7. While holding the thread end, press the "START/STOP" button. Wind the thread a few times around the bobbin and press the "START/STOP" button again. Trim the excess thread from the top of the bobbin after the machine stops.

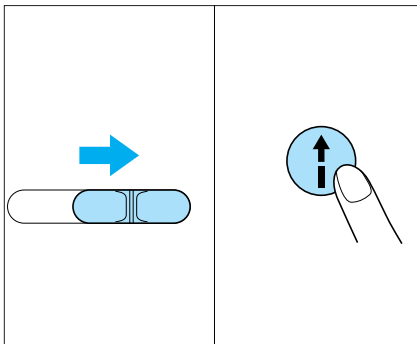

8. Set the speed to maximum.

9. Press the "START/STOP" button. The bobbin will stop spinning when bobbin winding is finished.

10. When the bobbin stops spinning, press the "START/STOP" button to stop the sewing machine.

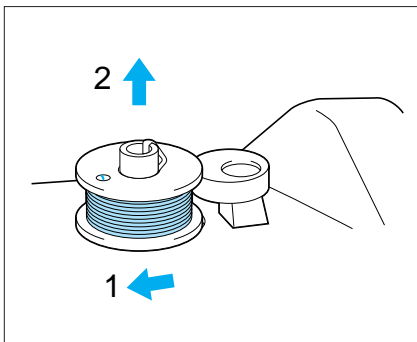

11. Push the bobbin shaft to the left. Remove the bobbin.

Setting the bobbin

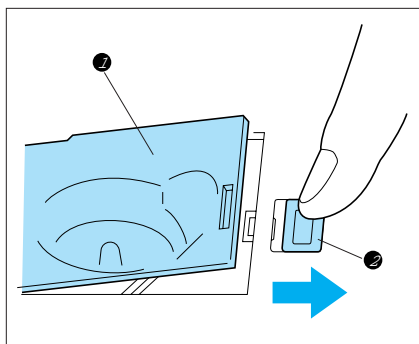

- Slide open the bobbin cover.

- ① Bobbin cover
- ② Bobbin cover release button

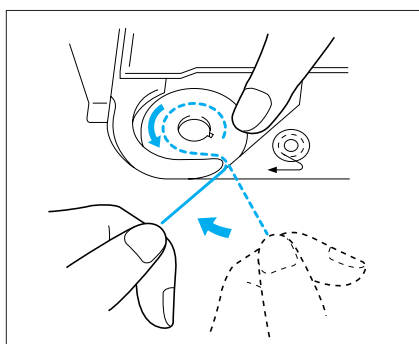

- Insert the bobbin into the shuttle with the thread direction as noted in the diagram.

CAUTION

Always make sure the bobbin is inserted so the thread feeds out of the bobbin in the correct direction. Setting the bobbin in backwards could result in poor bobbin tension, broken needles and possibly injury.

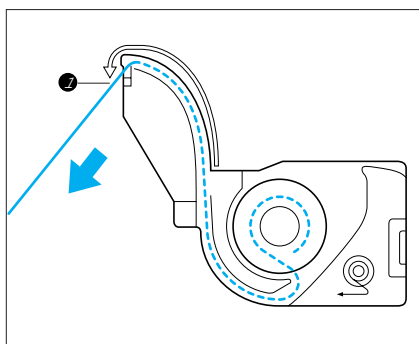

- Guide the thread end through the slit, then pull the thread toward you to cut off any excess thread.

- ① Built-in thread cutter

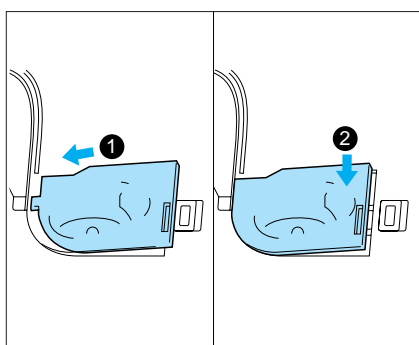

- Close the bobbin cover by placing the left end in place and pressing down lightly on the right end so that it snaps into place.

- * Sewing can begin without pulling out the bobbin thread.

UPPER THREADING

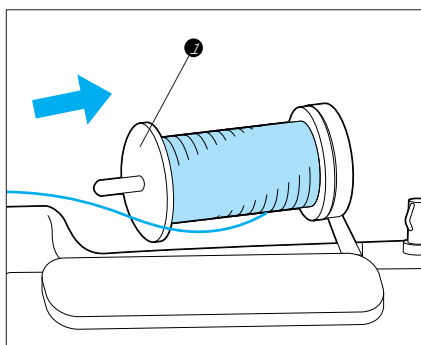
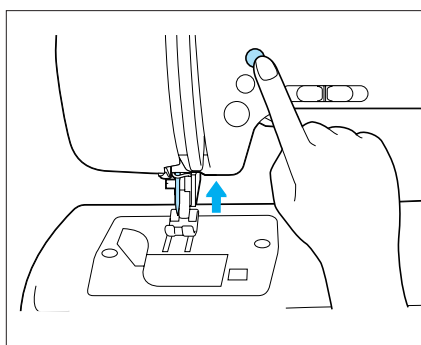
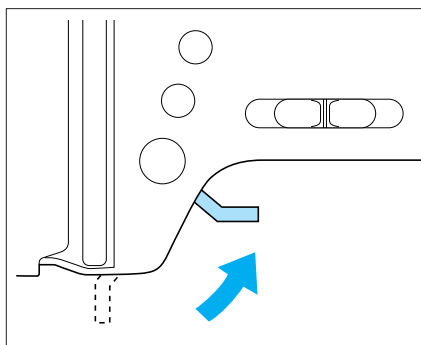
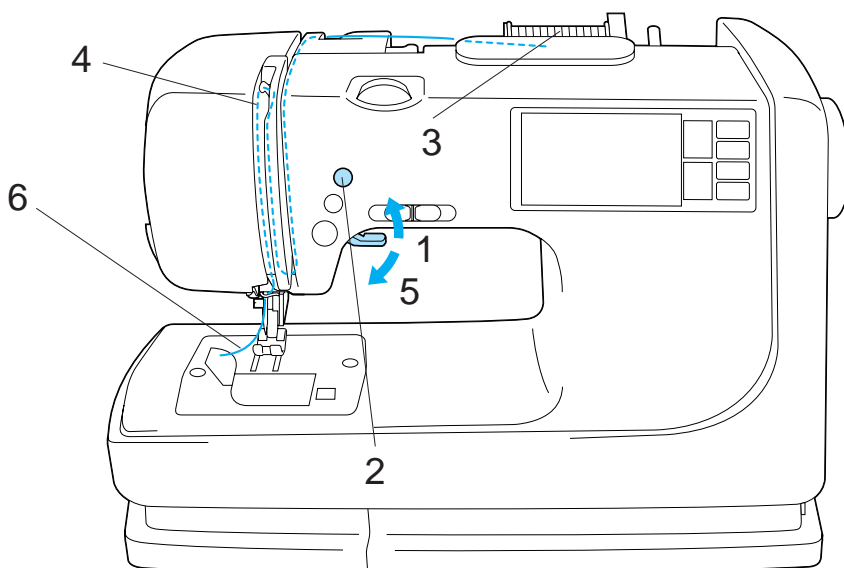

CAUTION

Always make sure to thread the machine properly as shown in the directions. If the machine is not threaded properly, the thread could get stuck, needles could break and bodily injury could result.

1. Raise the presser foot using the presser foot lever.
2. Press the “NEEDLE POSITION” button to raise the needle to the up position.
3. Set the thread spool. The thread end should come from the bottom front of the spool. The spool cap closest to the thread spool size should be used to hold the spool securely on the spool post.

- ① Spool cap

CAUTION

While sewing and embroidering, be sure that the spool pin is pulled out and pushed toward the back of the sewing machine.

Contents

Setting Up

Basic Sewing
Machine
Operation

Utility Stitches

Embroidering

Maintenance

Troubleshooting

Error
Messages

Sewing Chart

Patterns
(Programmed
In Machine)

Patterns
(Memory Card)

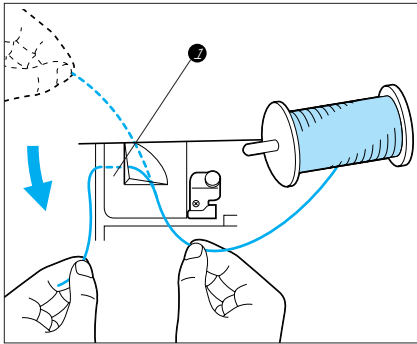

4. Guide the thread as illustrated by the numbers and arrow marks on the machine. Threading is easy if you hold the thread gently with your right hand while guiding the end of the thread with your left hand.

- ① Run the thread all the way through the thread guides.

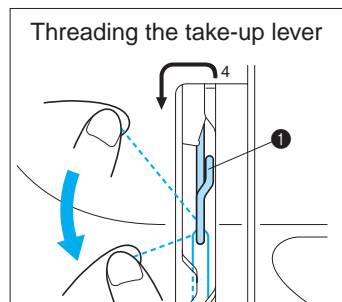
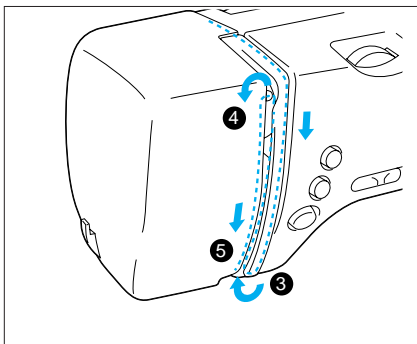

- ① Thread take-up lever

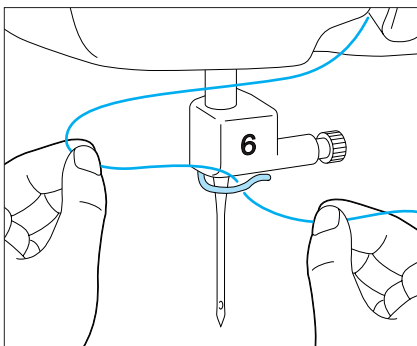

- * Threading is easy if you hold the thread gently with your left hand while guiding the end of the thread with your right hand.

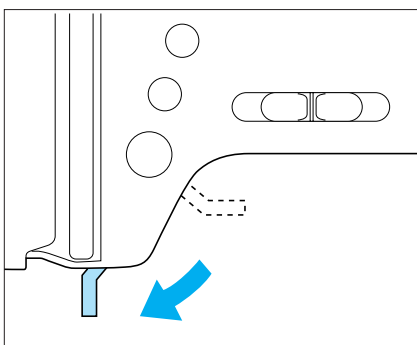

5. Lower the presser foot.

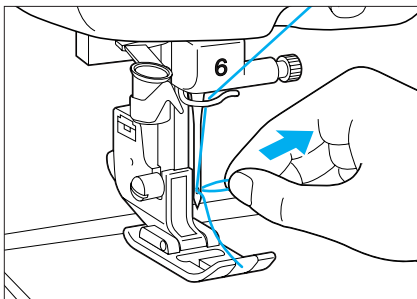
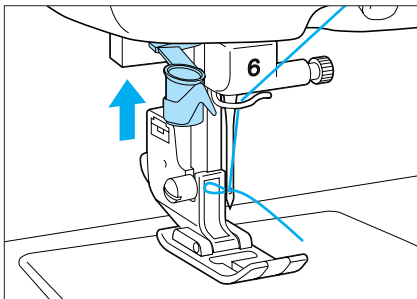
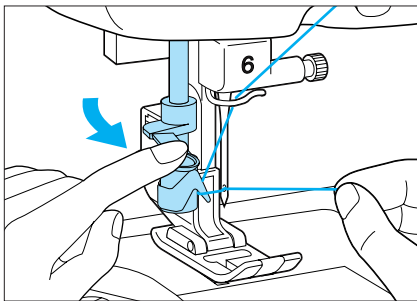
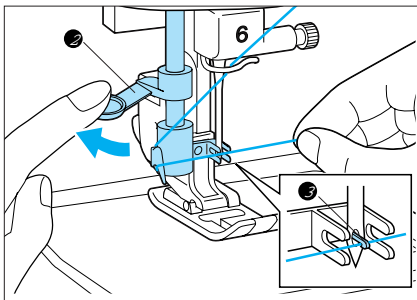
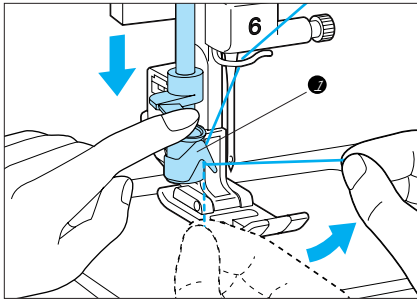

6. Run thread through the guide above the needle.

HOW TO USE THE AUTOMATIC NEEDLE THREADER

CAUTION

- Be careful not to turn the machine on while using the automatic needle threader.
- Use the automatic needle threader with size #11-16 sewing machine needles. Use the quick reference chart (p. 35) to make sure you're using the right needle.

① Lower the needle threader lever all the way down using your left index finger. (Pass thread to the right.)

① Guide (Large hook)

② Push the automatic needle threader lever to the back, pass the third hook through the eye of the needle, then scoop the thread up from below and through the third hook.

② Needle threader lever

③ Thread hook

③ While gently holding the thread, pull the needle threader lever toward you.

④ Simultaneously release both thread and automatic needle threader lever. The threading hook will pass the thread through the eye of the needle.

⑤ Pull the thread towards the rear to finish the upper threading.

CAUTION

Be careful not to force the thread and bend or damage the needle.

7. Pass the thread underneath the presser foot and pull it out from the rear of the machine by about 5 cm (13/64").

STARTING AND STOPPING SEWING

“START/STOP” button

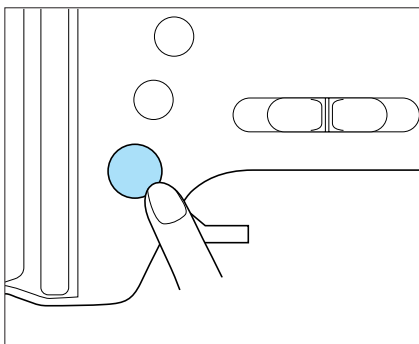

1. Place the fabric under the presser foot, lower the presser foot, and then press the “START/STOP” button. The sewing machine starts sewing.

- * Adjust speed by sliding the speed control lever.
- * Sewing continues at low speed while the button is pressed.

2. And then press it once more to stop the machine.

Foot controller

CAUTION

Do not allow fabric pieces and dust to collect in the foot controller. Doing so could cause a fire or an electric shock.

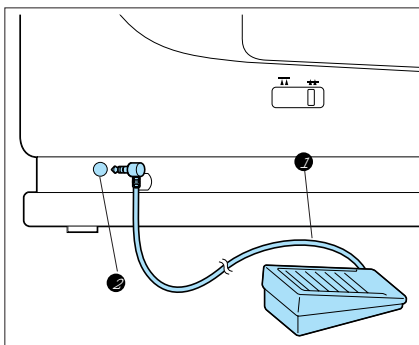

1. Turn the power off and plug the foot controller plug into the jack on the back of the machine.

- * The foot controller can not be used during machine embroidery.

- ① Foot controller
- ② Foot controller jack

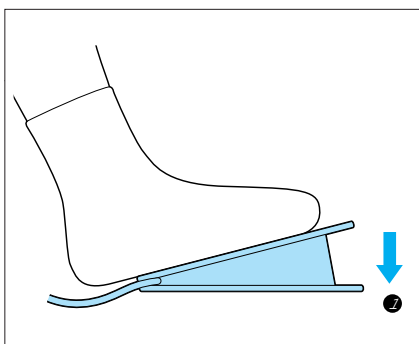

2. When the foot controller is depressed lightly, the machine will run at a low speed.

- * The speed selected by the speed control lever on the body of the machine will be the maximum speed of the foot controller.

- ① Faster

3. When pressure on the foot controller is released, the machine will stop.

- * When the foot controller is being used, the “START/STOP” button has no effect on the sewing.

Note (For U.S.A. only)

Foot controller: Model N5V

This foot controller can be used for sewing machine model PE-300S.

STITCH SELECTION (UTILITY STITCHES)

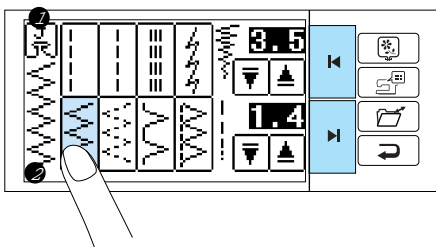

Press the “**◀**” key and “**▶**” keys to get to the screen of the stitch you wish to use. Then press the desired stitch to select it.

- ① Presser foot symbol
* Replace with the presser foot with the letter indicated.
- ② Pattern being selected

Stitches

● Straight (Left) 	● Straight (Middle) 	● Triple stitch 	● Stretch stitch
● Zigzag 	● Elastic zigzag 	● Overcasting 	● Overcasting
● Blind hem stitch 	● Blind hem stitch 	● Patchwork stitch 	
● Buttonhole 		● Bar tack 	● Applique
● Scallop 	● Triple zigzag 		
● Decorative stitch 			

TRIAL SEWING

CAUTION

- Be aware of the needle at all times while sewing, and keep your hands away from all moving parts such as the needle, balance wheel and thread take-up lever, otherwise injury may result.
- Do not pull or push the fabric too hard while sewing, otherwise injury may result.
- Never use bent needles. Such needles can easily break, which could result in injury.

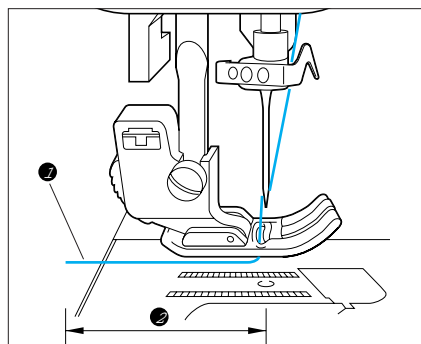
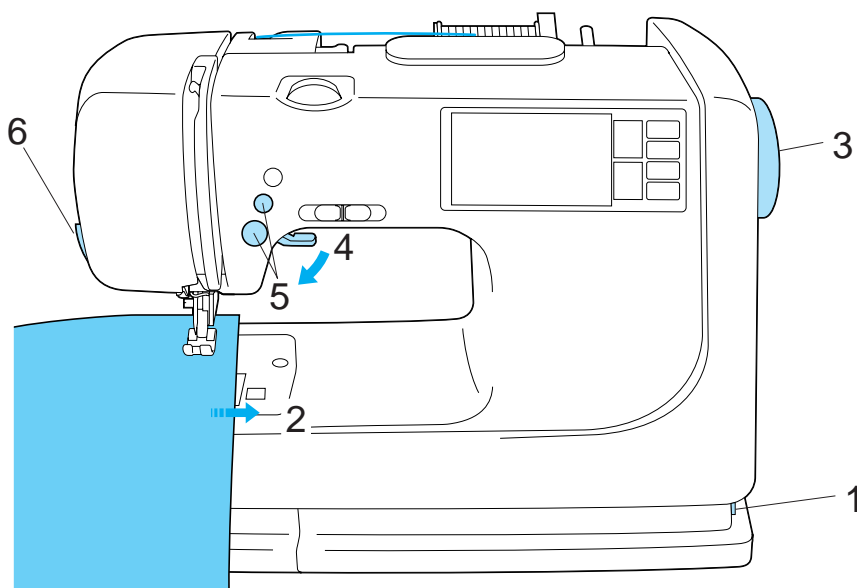

1. When the machine is turned on, the straight stitch (left) is always selected.
2. Pass the thread underneath the presser foot and pull it out from the rear of the machine by about 5 cm.

- ① Upper thread
- ② 5 cm (13/64")

- * Sewing can begin without pulling out the bobbin thread.
- * Use the J presser foot.

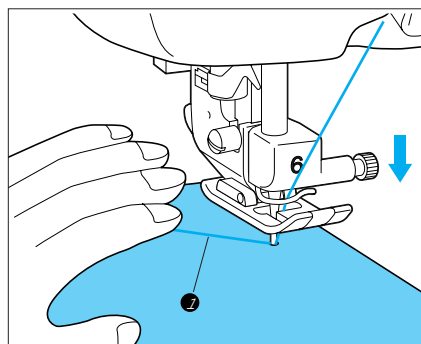

3. While pressing down on the thread and the fabric with your left hand, turn the balance wheel with your right hand to lower the needle to the sewing start position.

- ① Thread

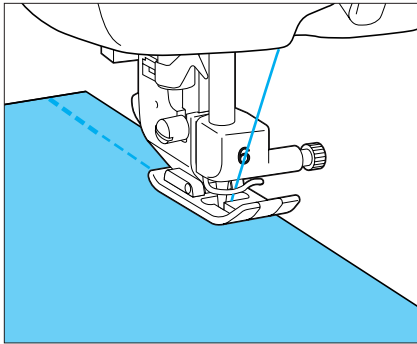

4. Lower the presser foot. Press the “REVERSE STITCH” button to sew a reverse stitch, and then press the “START/STOP” button. The machine will start sewing at slow speed.

- * Sew reverse stitches at the beginning and end of stitches to reinforce them.

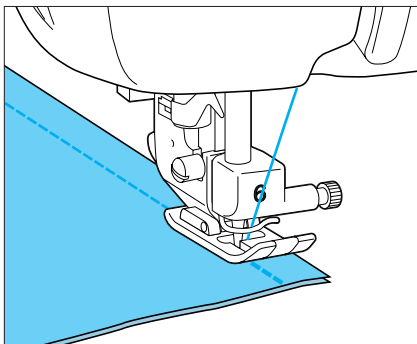

5. When sewing is completed, press the “REVERSE STITCH” button to sew a reverse stitch.

- * Reverse stitches are sewn while the “REVERSE STITCH” button is pressed.
- * Sewing in reverse is carried out at a slow sewing speed.
- * Sews in place when sewing any stitch other than a straight stitch or zigzag stitch.

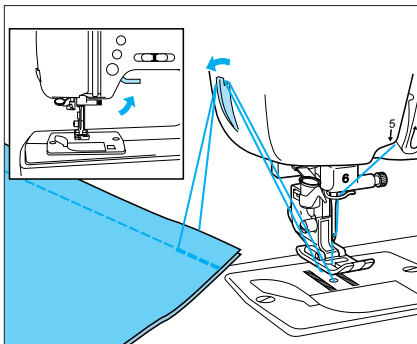



6. Raise the presser foot, remove the fabric and cut the thread.

STITCH WIDTH AND STITCH LENGTH

Your machine will automatically set stitch length and width when a stitch is selected. See the following instructions if you wish to further adjust stitch length or width.

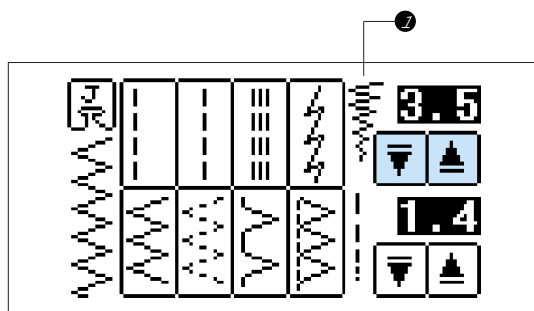
Adjusting the stitch width



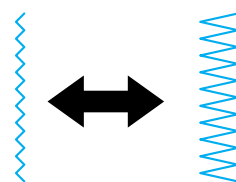

The two arrow buttons next to the stitch width mark (top pair of arrows) adjust stitch width. Press “” key for narrower widths and “” key for wider stitch widths.

① Stitch Width

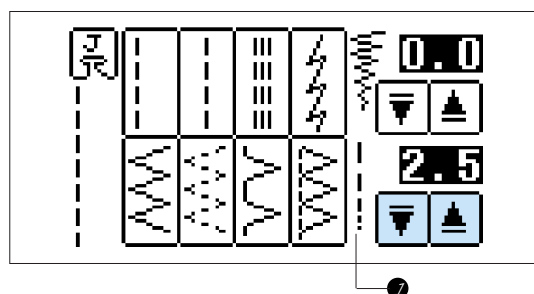

Adjusting the stitch length







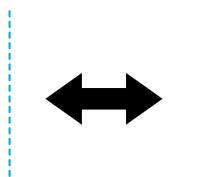



























The two arrow buttons next to the stitch length mark (bottom pair of arrows) adjust stitch length. Press “” key for shorter lengths and “” key for longer stitch lengths.

① Stitch Length



Quick adjustment reference chart for stitch width and stitch length

STITCH		Stitch width [mm (inch.)]		Stitch length [mm (inch.)]	
		Auto.	Manual	Auto.	Manual
	Straight (Left)	0.0 (0.0)	0.0 — 5.0 (0.0 — 13/64)	2.5 (3/32)	0.2 — 4.0 (1/64 — 5/32)
	Straight (Middle)	—	—————	2.5 (3/32)	0.2 — 4.0 (1/64 — 5/32)
	Triple stitch	0.0 (0.0)	0.0 — 5.0 (0.0 — 13/64)	2.5 (3/32)	1.5 — 2.5 (1/16 — 3/32)
	Stretch stitch	1.0 (3/64)	1.0 — 3.0 (3/64 — 1/8)	2.5 (3/32)	1.0 — 4.0 (3/64 — 5/32)
	Zigzag	3.5 (9/64)	0.0 — 5.0 (0.0 — 13/64)	1.4 (1/16)	0.0 — 4.0 (0 — 5/32)
	Elastic zigzag	5.0 (13/64)	1.5 — 5.0 (1/16 — 13/64)	1.0 (3/64)	0.2 — 4.0 (1/64 — 5/32)
	Overcasting	3.5 (9/64)	2.5 — 5.0 (3/32 — 13/64)	2.0 (5/64)	1.0 — 4.0 (3/64 — 5/32)
	Overcasting	5.0 (13/64)	2.5 — 5.0 (3/32 — 13/64)	2.5 (3/32)	1.0 — 4.0 (3/64 — 5/32)
	Blind hem stitch	0.0 (0.0)	+3 — -3 (→3) (3←)	2.0 (5/64)	1.0 — 3.5 (3/64 — 9/64)
	Blind hem stitch	0.0 (0.0)	+3 — -3 (→3) (3←)	2.0 (5/64)	1.0 — 3.5 (3/64 — 9/64)
	Buttonhole	5.0 (13/64)	3.0 — 5.0 (1/18 — 13/64)	0.4 (1/64)	0.2 — 1.0 (1/64 — 3/64)
	Buttonhole	5.0 (13/64)	3.0 — 5.0 (1/18 — 13/64)	0.4 (1/64)	0.2 — 1.0 (1/64 — 3/64)
	Buttonhole	5.0 (13/64)	3.0 — 5.0 (1/18 — 13/64)	1.5 (1/16)	1.0 — 3.0 (3/64 — 1/8)
	Bar tack	2.0 (5/64)	1.5 — 3.0 (1/16 — 1/8)	0.4 (1/64)	0.2 — 1.0 (1/64 — 3/64)
	Applique	3.5 (9/64)	2.5 — 5.0 (3/32 — 13/64)	2.5 (3/32)	1.6 — 2.5 (1/16 — 3/32)
	Scallop	5.0 (13/64)	2.5 — 5.0 (3/32 — 13/64)	0.4 (1/64)	0.2 — 1.0 (1/64 — 3/64)

STITCH		Stitch width [mm (inch.)]		Stitch length [mm (inch.)]	
		Auto.	Manual	Auto.	Manual
	Patchwork stitch	5.0 (13/64)	2.5 — 5.0 (3/32 — 13/64)	2.5 (3/32)	1.0 — 2.5 (3/64 — 3/32)
	Fagoting	5.0 (13/64)	2.5 — 5.0 (3/32 — 13/64)	2.5 (3/32)	1.0 — 2.5 (3/64 — 3/32)
	Triple zigzag	4.0 (5/32)	0.0 — 5.0 (0 — 13/64)	2.5 (3/32)	1.0 — 4.0 (3/64 — 5/32)
	Decorative stitch	5.0 (13/64)	2.5 — 5.0 (3/32 — 13/64)	0.4 (1/64)	0.2 — 1.0 (1/64 — 3/64)
	Decorative stitch	5.0 (13/64)	2.5 — 5.0 (3/32 — 13/64)	0.4 (1/64)	0.2 — 1.0 (1/64 — 3/64)
	Decorative stitch	5.0 (13/64)	2.5 — 5.0 (3/32 — 13/64)	0.4 (1/64)	0.2 — 1.0 (1/64 — 3/64)
	Decorative stitch	5.0 (13/64)	2.0 — 5.0 (5/64 — 13/64)	1.6 (1/16)	1.0 — 4.0 (3/64 — 5/32)
	Decorative stitch	5.0 (13/64)	3.0 — 5.0 (1/8 — 13/64)	2.5 (3/32)	2.0 — 4.0 (1/16 — 5/32)
	Decorative stitch	5.5 (7/32)	1.5 — 5.0 (1/16 — 13/64)	2.5 (3/32)	1.5 — 4.0 (1/16 — 5/32)
	Decorative stitch	4.0 (5/32)	0.0 — 5.0 (0 — 13/64)	2.5 (3/32)	1.0 — 4.0 (3/64 — 5/32)
	Decorative stitch	1.5 (1/16)	0.5 — 2.5 (1/32 — 3/32)	1.4 (1/16)	0.8 — 4.0 (1/32 — 5/32)
	Decorative stitch	0.0 (0.0)	0.0 — 5.0 (0 — 13/64)	2.5 (3/32)	1.0 — 4.0 (3/64 — 5/32)
	Decorative stitch	5.0 (13/64)	0.0 — 5.0 (0 — 13/64)	2.5 (3/32)	1.0 — 4.0 (3/64 — 5/32)
	Decorative stitch	5.0 (13/64)	0.0 — 5.0 (0 — 13/64)	2.5 (3/32)	1.0 — 4.0 (3/64 — 5/32)
	Decorative stitch	5.0 (13/64)	0.0 — 5.0 (0 — 13/64)	2.5 (3/32)	1.0 — 4.0 (3/64 — 5/32)
	Decorative stitch	5.0 (13/64)	0.0 — 5.0 (0 — 13/64)	2.5 (3/32)	1.0 — 4.0 (3/64 — 5/32)

*—: Non-adjustable

THREAD TENSION

Use the tension dial to adjust thread tension in accordance to the fabric and thread you are using.

- For stitches with fairly small stitch lengths, such as the satin stitch and buttonhole stitching, you can get a better stitch by slightly reducing tension.
- Use the tension dial to adjust thread tension for lightweight or heavyweight fabrics and for gathers.

Correct tension

- * Thread tension is automatically set to the most appropriate point irrespective of the chosen fabric and thread. Correct tension is important because too much or too little tension will weaken your seams or cause your fabric to pucker.

- 1 Reverse side
- 2 Surface
- 3 Upper thread
- 4 Bobbin thread

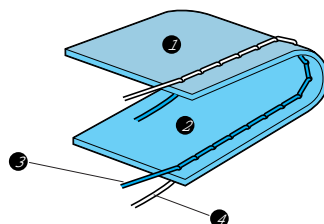

Tightening the upper thread tension

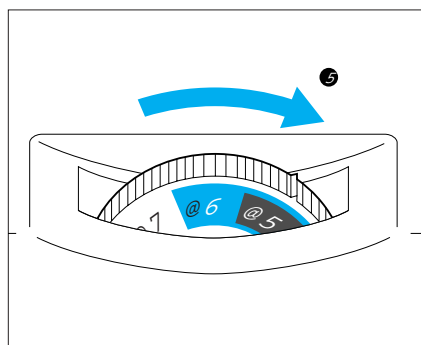

Turn the tension dial to the right to tighten the upper thread tension.

- 1 Locks appears on reverse side of fabric.
- 2 Surface
- 3 Upper thread
- 4 Bobbin thread
- 5 Tighter

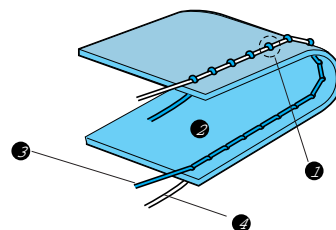

Loosening the upper thread tension

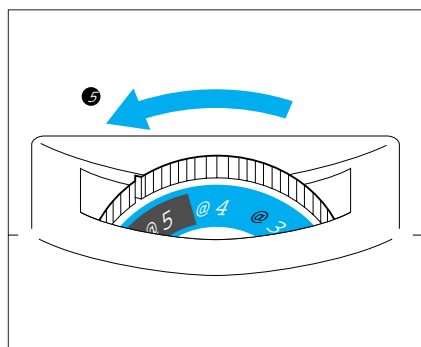

Turn the tension dial to the left to loosen the upper thread tension.

- 1 Locks appear on surface of fabric.
- 2 Surface
- 3 Upper thread
- 4 Bobbin thread
- 5 Looser

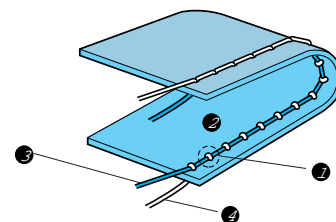

- * The **5** setting on the tension dial is a guide for working normal fabrics (medium weight). However, the actual stitch tension you'll want to use will vary according to the fabric and thread you are using, so you should always sew a stitch sample and adjust stitch tension before beginning on the actual piece to be worked.

- * The machine may stop sewing if tension is set extremely low. This is not a sign that there is anything wrong with your machine. Simply adjust to the correct stitch tension and begin again.

PRESSER FOOT

Changing the presser foot

CAUTION

Always make sure to turn the machine off and unplug it when changing presser feet. If the power accidentally comes on, the machine might start running and bodily injury could result.

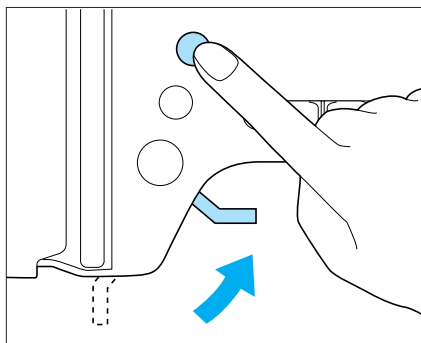

1. Push the “NEEDLE POSITION” button to raise the needle, and then turn off the power.

2. Raise the presser foot lever.

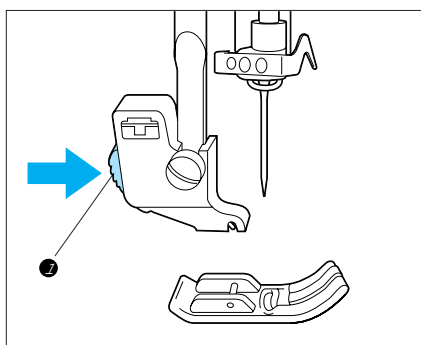

3. Press the black button located at the back of the presser foot holder to release the foot.

① Presser foot holder

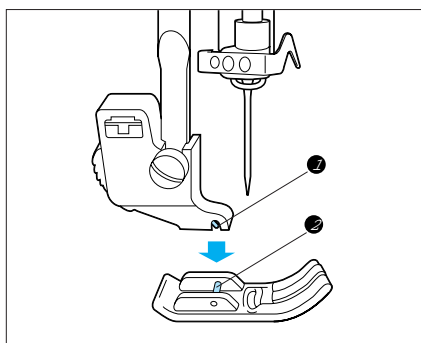

4. Place the presser foot pin directly below the holder-end and lower the presser foot lever to attach the presser foot.

① Holder-end

② Foot pin

Changing the Embroidery foot and the zipper foot

Embroidery foot "Q"

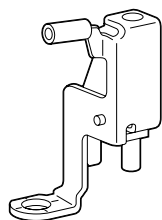

Zipper foot "I"

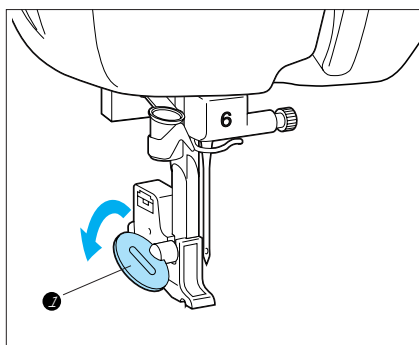
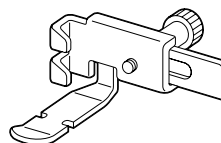

1. Push the "NEEDLE POSITION" button to raise the needle, and then turn off the power.

2. Remove the screw on the presser foot holder.

① Disk-shaped screwdriver

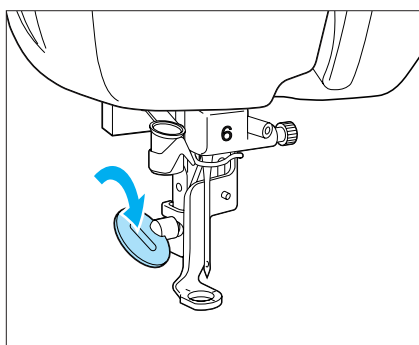

3. Change the foot and screw back on tightly.

FEED DOGS

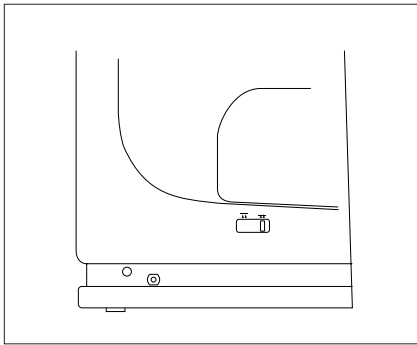

The feed dog adjustment lever can be seen at the back of the sewing machine. Sliding the lever to the left will lower the feed dogs, for example during button sewing. If you wish to continue sewing normally, slide the lever to the right in order to raise the feed dogs.

The feed dogs cannot be raised if the balance wheel does not turn, even if the lever is slid to the right.

NEEDLE

CAUTION

- Always make sure to turn the machine off before changing needles. There is a danger of injury if the machine accidentally starts running during this operation.
- Never use bent or damaged needles. If the needle breaks while sewing, the broken tip could fly away from the machine and cause injury.

Checking the needle

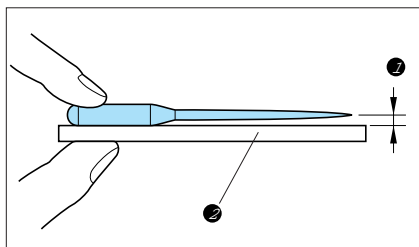

Place the needle on a flat surface and check whether the space between the needle and the flat surface is parallel or not.

If the space is not parallel then the needle is bent and should be thrown away to prevent damage to your project or to the machine.

- ① Space between the needle and the flat surface
- ② Flat surface (needle plate, glass, ruler, etc.)

Installing the needle securely

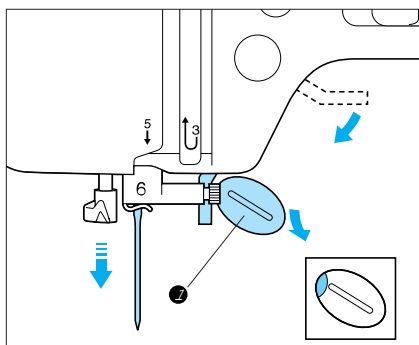

1. Turn off the power.
2. Lower the presser foot.
3. Loosen the needle clamp screw with a screwdriver. Pull out the needle.

- ① Disc-shaped screwdriver

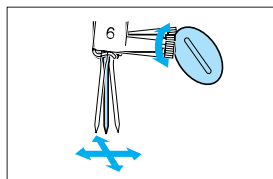

CAUTION

Do not loosen or tighten the needle clamp screw with a strong force, otherwise it may be damaged.

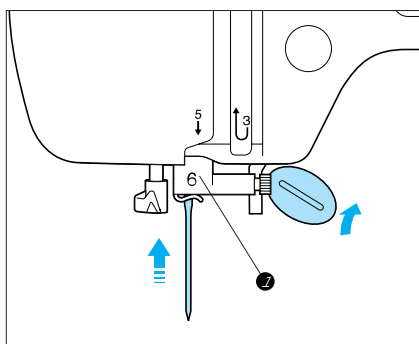

4. With the flat side of the needle facing the back, insert the needle as far as it will go up against the needle stopper.
5. Fasten the screw securely with a screwdriver.

- ① Needle stopper

FABRIC/THREAD/NEEDLE COMBINATION CHART

Sewing fabrics		Thread		Needle size
		Type	Size	
Medium	Broad cloth	Cotton	60-80	11-14
	Taffeta/Satin	Synthetic mercerized	60-80	
	Flannel, Gabardine	Silk	50-80	
Lightweight	Lawn	Cotton	60-80	9-11
	Georgette	Synthetic mercerized	60-90	
	Challis	Silk	50-80	
Heavy	Denim	Cotton	40-50	14-16
	Corduroy	Synthetic mercerized	50	
	Tweed	Silk	50	
Stretch	Jersey	Synthetic mercerized		Golden needle
	Tricot	(Thread for knits)		11-14
Woven fabrics that unravel easily		Cotton	50-80	9-14
		Synthetic mercerized	50-80	
		Silk	50-80	
For top stitching		Synthetic mercerized	30	14-16
		Silk	30	

- * Use the golden needle when sewing on stretch fabrics and fabrics where skipped stitches easily occur.
- * Use a needle with a size between 14 and 16 when sewing with transparent nylon thread.

Note

Always follow the above chart when choosing fabric, thread and needle combinations. Failure to do so could result in uneven stitching, puckered fabric or skipped stitches. Furthermore, use of a thin needle (size #9-11) on a heavyweight fabric such as denim could cause bent or broken needles.

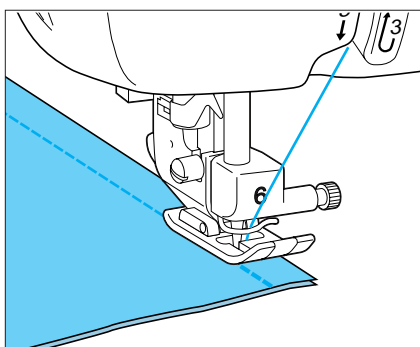
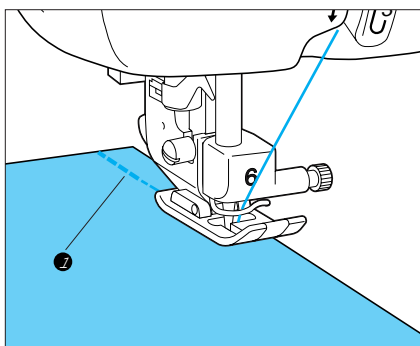
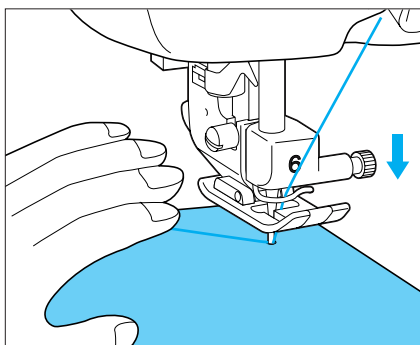
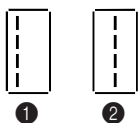

- ① Straight (Left)
- ② Straight (Middle)

1. Attach the J foot. Handle thread and fabric with your left hand while turning the balance wheel with the right. Pierce the needle through the fabric as shown.

2. Lower the presser foot. While pressing the reverse stitch button, sew 3-4 stitches in reverse to make a reinforcement stitch. Then release the "REVERSE STITCH" button and press the "START/STOP" button to begin sewing.

- ① Reinforcement stitch (3-4 stitches)



3. At the end of a seam, press the "REVERSE STITCH" button again to sew another reinforcement stitch.

- * Reverse stitches are sewn while the "REVERSE STITCH" button is pressed.
- * Sewing in reverse is carried out at a slow sewing speed.

4. Raise the presser foot, remove the fabric and cut the thread.

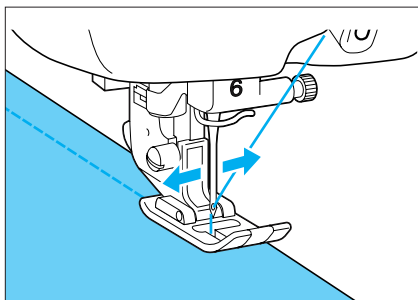
Changing needle position



When sewing a straight stitch along the left edge of the fabric, you can press the stitch width arrows to move the needle position from left to right. This allows you to adjust the distance of the stitches from the edge of the fabric, while still allowing you to run the edge of the foot along the edge of the fabric.  

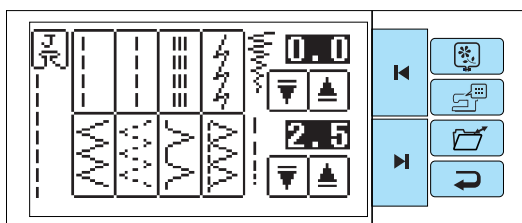

Sewing corners

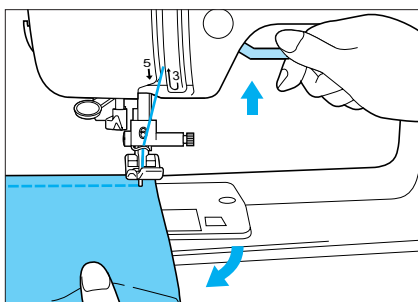

Keep the needle at the corner of the fabric, then raise the presser foot and turn the fabric.

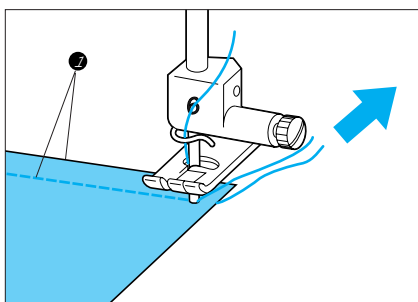

When stitching a hem less than .5 cm in width, baste corners, change directions and pull the thread behind the foot while sewing.

- ① Less than 0.5 cm

Sewing curves

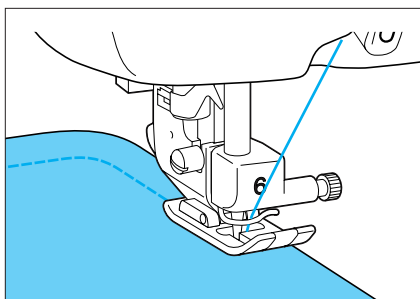

Sew slowly, while keeping the seams parallel with the fabric edge as you guide the fabric around the curve.

Sewing thick seams

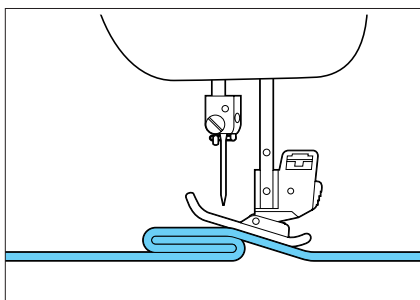

When the foot angles up at the approach of a thick seam, lower the needle and raise the presser foot. Level the presser foot by placing a "shim" (folded fabric or cardboard) under the back of the presser foot. Lower presser foot and continue stitching.

Sewing thick fabric

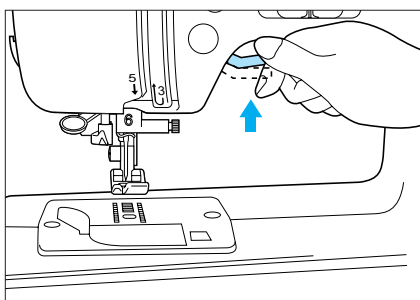

When you raise the presser foot lever further, the presser foot is raised to a higher position to handle thicker fabrics. With the presser foot in the up position, raise the presser foot lever higher to make room for thicker fabrics.

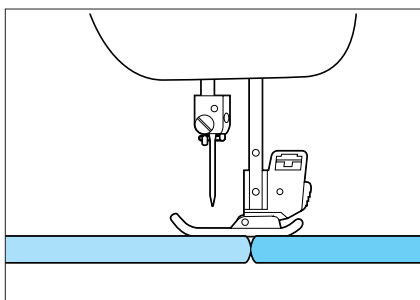

If the fabric will not feed at the beginning of sewing, place another piece of fabric with the same thickness at the back of the material.

Sewing thin fabric

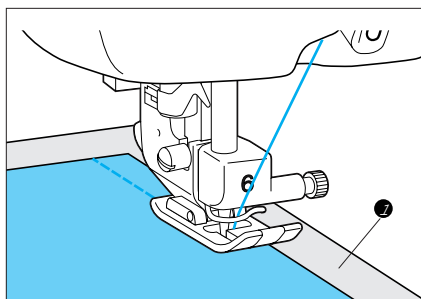

Place thin paper or stabilizer material under the fabric, and then start sewing.

- 1 Paper

Using the free arm

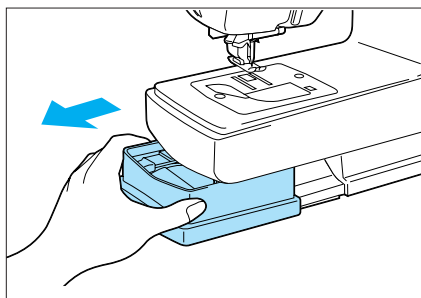

The free arm is handy when sewing hard-to-reach areas like hems and cuffs on pant legs. Remove the accessory case to use it.

STRETCH STITCH AND TRIPLE STITCH



1



2

- 1 Stretch stitch
- 2 Reinforced stitch

Stretch stitch

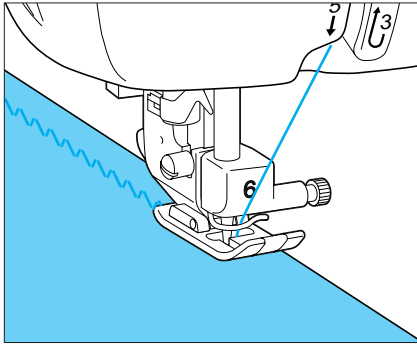

Use on knit fabrics that stretch. Do not stretch fabric while sewing with this stitch.

Triple stitch

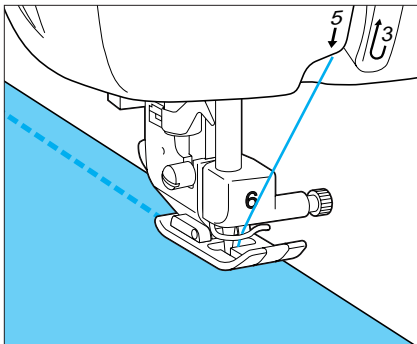

Use on high stress areas like the arm holes of sleeves and the crotch of slacks as a strengthening stitch.

Contents

Setting Up

Basic Sewing
Machine
Operation

Utility Stitches

Embroidering

Maintenance

Troubleshooting

Error
Messages

Sewing Chart

Patterns
(Programmed
In Machine)

Patterns
(Memory Card)



The zigzag stitch is handy for overcasting or working with applique and patchwork.



Zigzag

Overcasting (using a zigzag stitch)

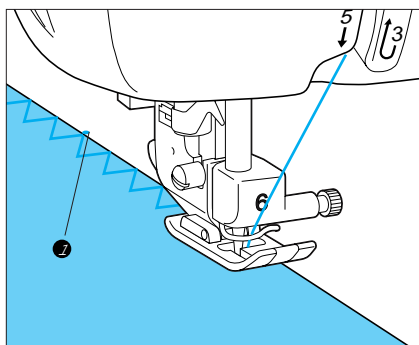

Sew the overcasting along the edge of the fabric so that the right hand side needle drop point is over the edge of the fabric.

- 1 Needle drop point

Applique (using a zigzag stitch)

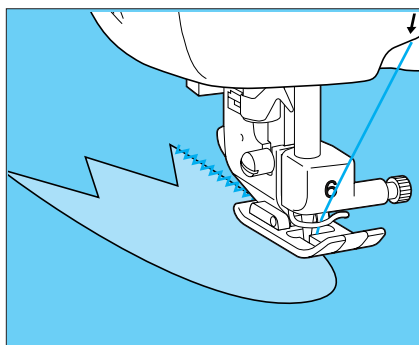

Attach the applique using adhesive or basting, then sew it.

Patchwork (for crazy quilt)

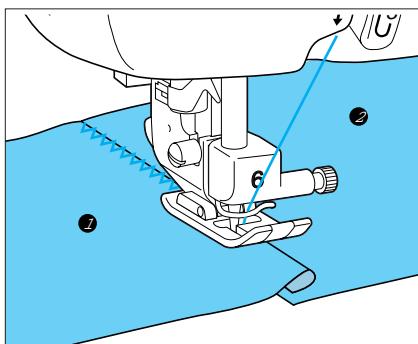

Turn back the desired width of fabric and position it over the lower fabric, then sew so that the stitch bridges both pieces of fabric.

- ① Upper fabric
- ② Lower fabric

Sewing a curve with a zigzag stitch

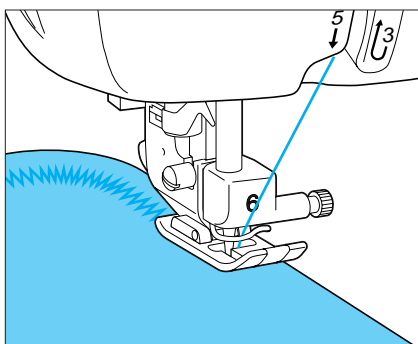

An attractive stitch can be achieved when sewing around corners by using a narrow stitch width.



Elastic zigzag

Attaching elastic bands

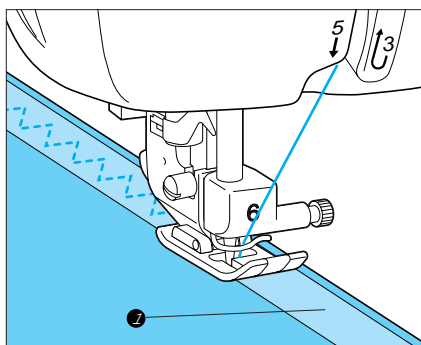

Stretch elastic while sewing.

- 1 Elastic Band

Overcasting

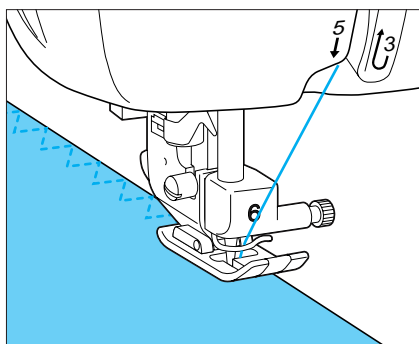

Use when sewing stretchable fabrics. Allow the needle to drop off over the edge of the fabric while sewing.

OVERCASTING



Caution

Always be sure to use the right foot for the stitch you are sewing. Using the wrong foot could cause the needle to hit the foot while sewing, which could result in broken needles and possible injuries.

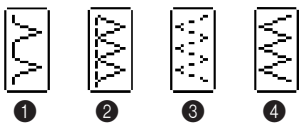

- ① Overcasting (Presser foot “G”)
- ② Overcasting (Presser foot “G”)
- ③ Elastic zigzag (Presser foot “J”)
- ④ Zig zag (Presser foot “J”)

Overcasting

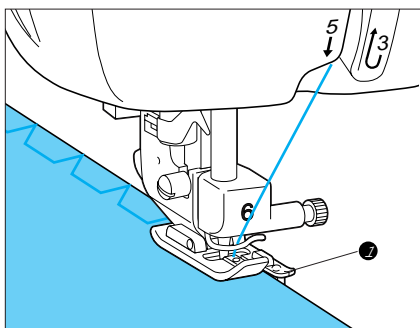

For use on medium or lightweight fabrics. Attach the G foot. Keep foot guide along edge of fabric while sewing hem as illustrated in the drawing.

- ① Guide

CAUTION

After the stitch width has been adjusted, turn the balance wheel by hand and check that the needle does not touch the presser foot.

If it does touch, the needle may break and cause an injury.



Overcasting

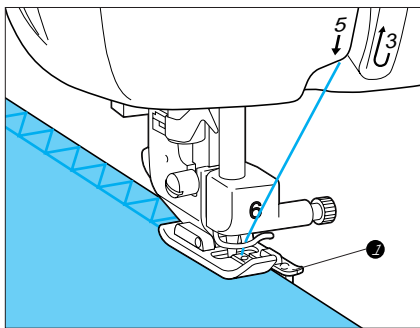

Combination straight stitch and overcast zigzag. Use on heavy-weight fabrics. Attach G foot. Keep foot guide along edge of fabric while sewing hem as illustrated in the drawing.

- ① Guide

CAUTION

After the stitch width has been adjusted, turn the balance wheel by hand and check that the needle does not touch the presser foot.

If it does touch, the needle may break and cause an injury.



Overcasting

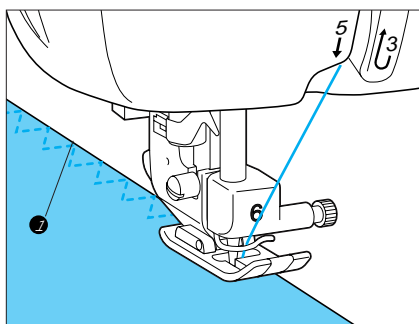

For use on stretchable fabrics. Attach J foot. Keep foot on the edge of fabric so that needle drops slightly over the edge of fabric while sewing.

- 1 Needle Drop Point

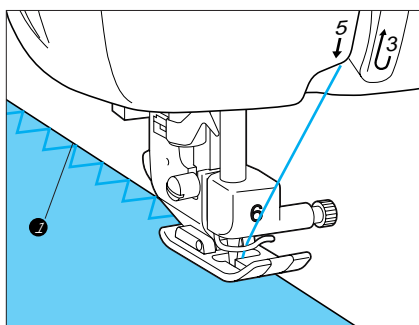

Overcasting



For use on a wide range of fabrics. Attach J foot. Keep foot on the edge of fabric so needle drops slightly over the edge while sewing.

- 1 Needle Drop Point



Use the  on stretch fabrics and the  for other fabrics.

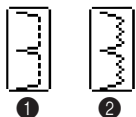

- ① Blind hem stitch
- ② Blind hem stitch

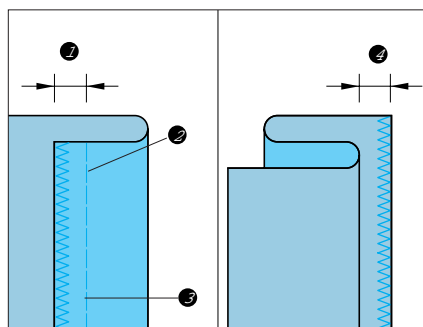

1. Fold the fabric and baste it as illustrated.

- ① 0.5 cm (1/64")
- ② Basting stitch
- ③ Overcasting
- ④ 0.5 cm (1/64")

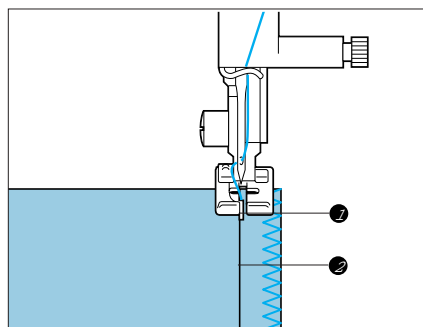

2. Attach presser foot "R". Lower the presser foot so that its guide meets the edge of the folded hem.

- ① Guide
- ② Folded hem

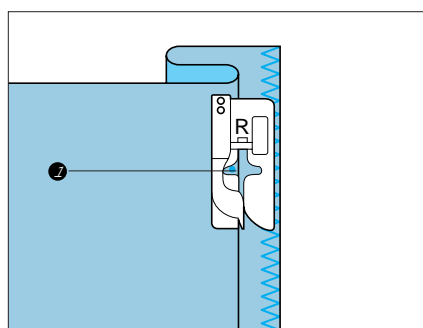

3. Adjust the needle position using the stitch width setting keys so that needle slightly catches the fold of the hem, and then sew the fabric.

- ① Needle drop position

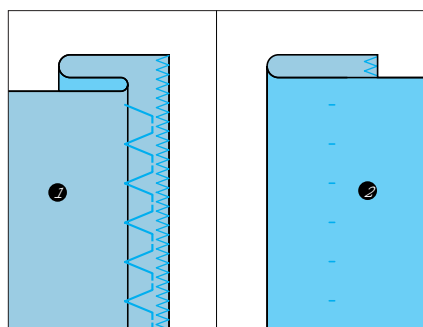

4. Turn over the fabric and remove the basting stitch.

- ① Reverse side
- ② Surface

If the needle does not catch the fold of hem enough.

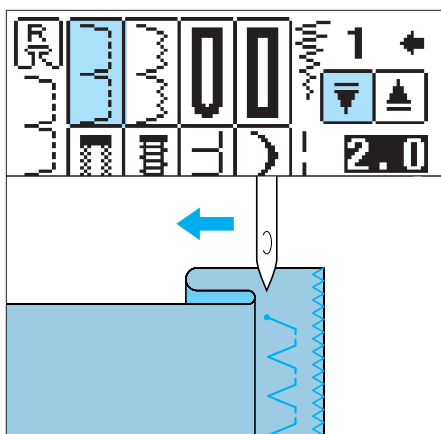

Touch the “” key stitch width setting key. This moves the needle closer to the fold.

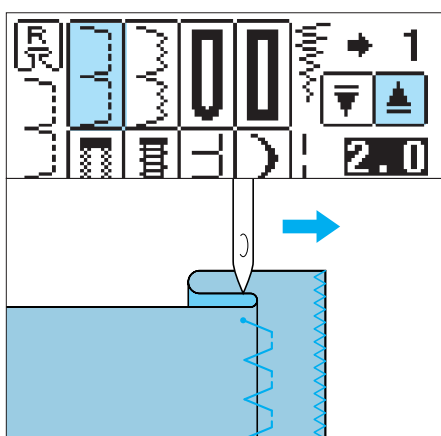

If the needle catches the fold of hem too much.



Touch the “” key stitch width setting key. This moves the needle away from the fold.

BUTTONHOLE STITCHES



Always make your stitch samples out of scraps from the fabric you will be using. For standard button holes, select . Select  sewing button holes into stretch fabrics and  for sideways buttonholes.

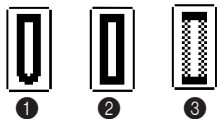

- ① Buttonhole
- ② Buttonhole
- ③ Buttonhole

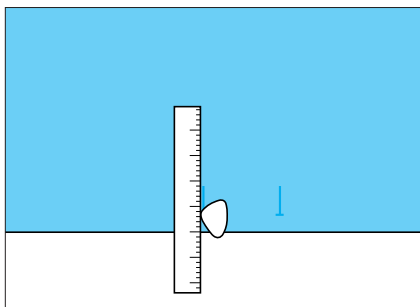

1. Mark the positions of the buttonholes on the fabric.

- * The maximum buttonhole length is 3 cm (1-3/16") (total of diameter + thickness of button).

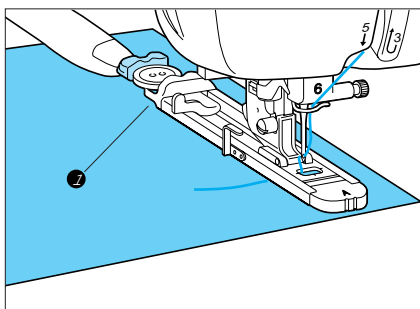

2. Draw out the button holder plate and insert the button.

- ① Button holder plate

- * Place a button on the buttonholer as illustrated to automatically gauge buttonhole size.

CAUTION
Pass the thread underneath the presser foot.

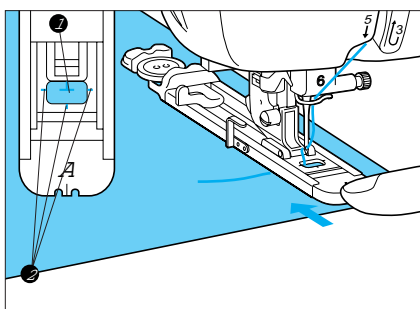

3. Raise the presser foot and adjust the fabric so that the red mark on the foot is over the starting mark of your buttonhole. Lower the presser foot into position.

- ① Mark on fabric for buttonhole position
- ② Red mark on presser foot

CAUTION
After the presser foot lever has been lowered, set the presser foot so that there is no gap behind the section marked with an "A", otherwise the size of the stitch will not be correct. To do this, push the presser foot towards the back of the machine as shown in the left figure.

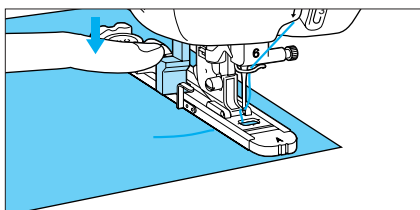
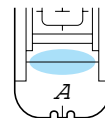

4. Lower the buttonhole lever and position it behind the metal bracket on the buttonhole foot.

- ① Metal bracket on the buttonhole foot

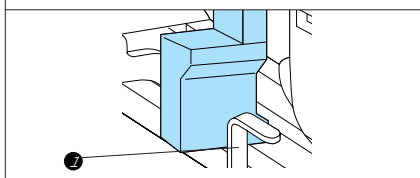

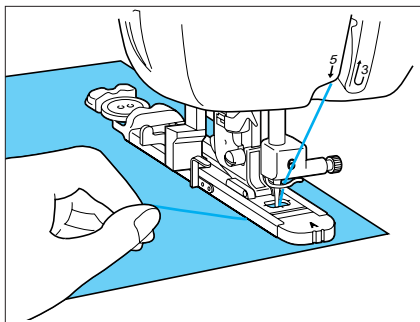

5. Press the “START/STOP” button to start the machine, while gently holding the end of the upper thread.

- * Gently, feed the fabric by hand.
- * The machine will stop with a reinforcement stitch automatically after sewing is completed.
- * Use a courser stitch density when sewing on heavyweight fabrics and other difficult fabrics.

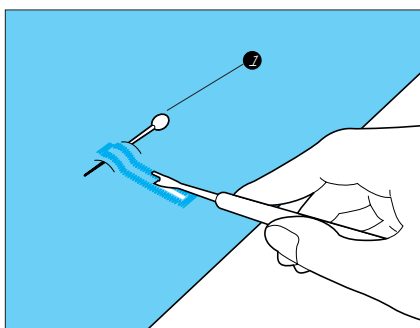

6. Insert a pin in front of the inside edge of both bar tacks. Insert the seam ripper into center of buttonhole. Cut towards the first pin. Then cut toward the other pin.

- ① Pin

Order of one cycle

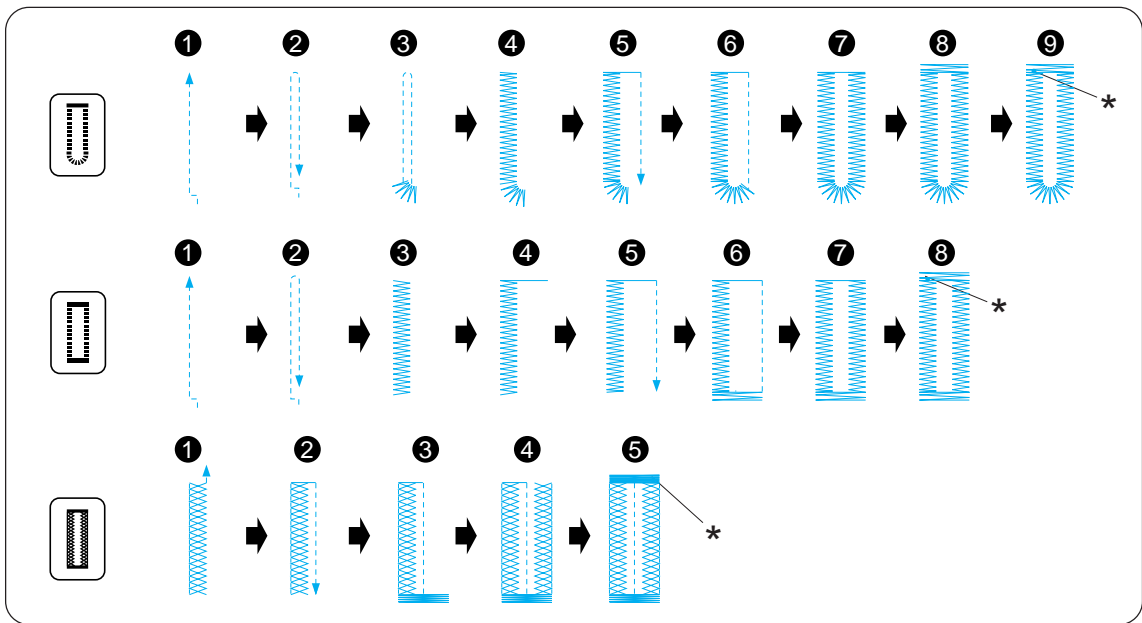

* Reinforcement stitch

Sewing stretch fabrics ()

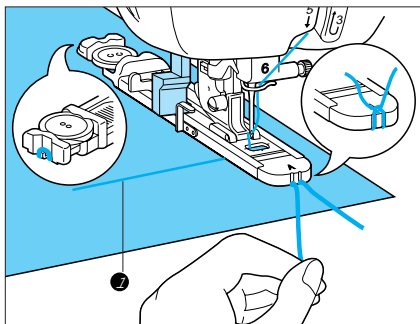

When sewing buttonholes onto stretch fabric, insert a gimp thread into the buttonhole seam (buttonholes only).

1. Hook the gimp thread onto the end of presser foot "A", insert it into the groove at the front of the presser foot and temporarily tie it there.

① Upper thread

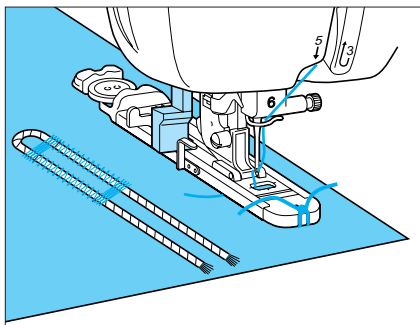

2. Lower the presser foot and start sewing.

* Set the stitch width to match the diameter of the gimp thread.

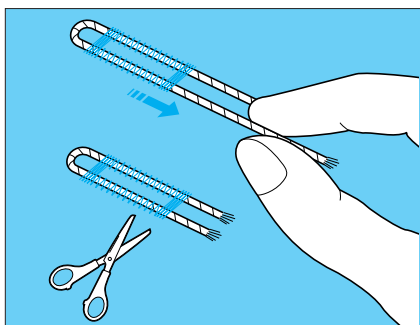

3. Once sewing is completed, pull the gimp thread gently to remove any slack, and trim any surplus length.

* Trim and remove any threads sewn through the center of the buttonhole with the seam ripper.

Buttons that do not fit into the guide plate (Odd-shaped buttons)

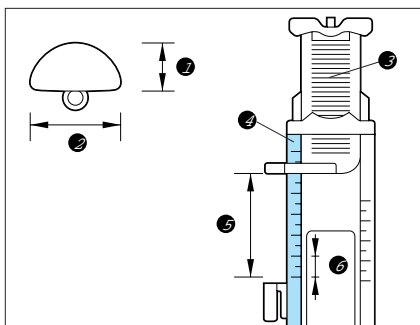

Use scale on the buttonholer foot to gauge buttonhole size. Buttonholer scale is graduated in half centimetres. Adjust size of buttonholes on scale according to diameter + thickness of buttons.

- ① Thickness [1 cm (3/8")]
- ② Diameter [1.5 cm (9/16")]
- ③ Button holder plate
- ④ Scale
- ⑤ Diameter + thickness [2.5 cm (1")]
[0.5 cm (13/64") in one scale.]
- ⑥ 0.5 cm (13/64")

Example: For a button with a diameter of 1.5 cm (9/16") and a thickness of 1 cm (3/8"), the scale should be set at 2.5 cm (1")



Use for reinforcing the openings of pockets, etc.



1

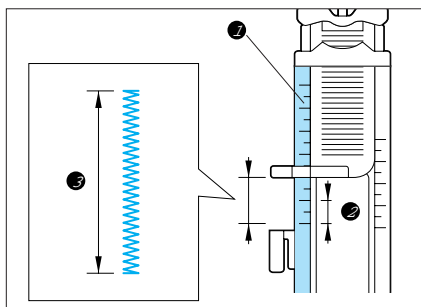

1 Bar tack

1. Attach presser foot "A" and set the size by measuring the area to be bar tacked.

- 1 Scale
- 2 0.5 cm (13/64")
- 3 Length of bar tack

* 0.5 to 3 cm (13/64" to 1-3/16") is suitable for bar tacking.
0.5 to 1 cm (13/64" to 3/8") is the normal size.

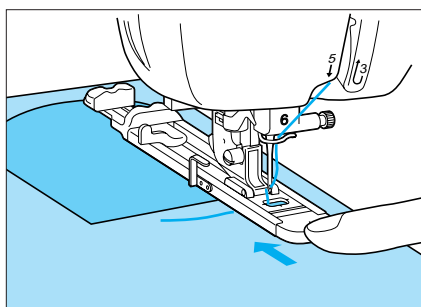

2. Position the pocket as illustrated with the top of the pocket facing you.

CAUTION

- After the presser foot lever has been lowered, set the presser foot so that there is no gap behind the section marked with an "A", otherwise the size of the stitch will not be correct. To do this, push the presser foot towards the back of the machine as shown in the figure.
- Pass the thread underneath the presser foot.

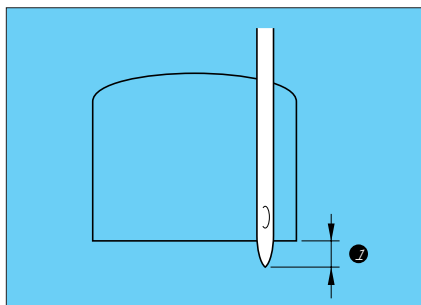
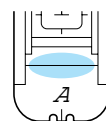

3. Check the first needle drop point and lower the presser foot.

- 1 2 mm (5/64")

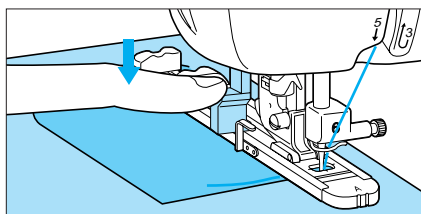

4. Lower the buttonhole lever and position it behind the metal bracket on the buttonhole foot.

- 1 Metal bracket on buttonhole foot

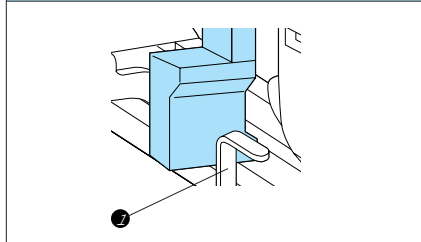

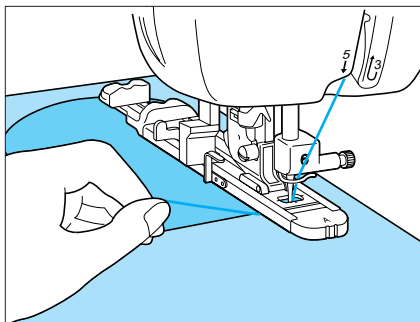

5. Start the machine while holding the end of the upper thread gently.

- * The machine will sew a reinforcement stitch and stop automatically after sewing is completed.

Thick fabrics

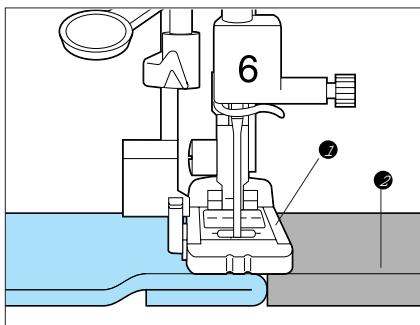

If the zipper slide gets in the way, lower the needle all the way through the cloth, lift the foot, and move the slider out of the way.

- ① Presser foot
- ② Cardboard

- * Use a larger stitch length when working with heavyweight fabrics that don't feed very easily.



- ① Applique
- ② Zig zag
- ③ Fagoting

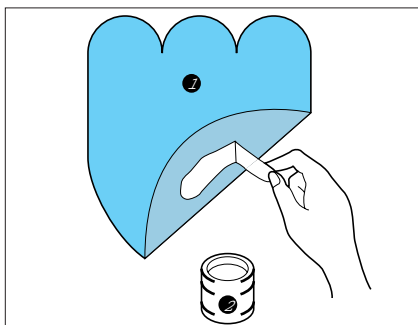

Preparations:

Attach the applique to the fabric. The applique should be attached with fabric glue or a basting stitch so that it will not move during sewing.

- ① Applique
- ② Fabric glue

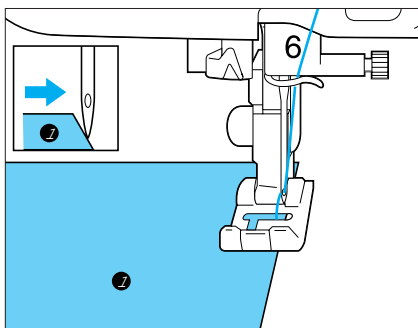

1. Attach presser foot "J". Make sure that the needle drop point is just outside the applique and then start sewing.

- ① Applique

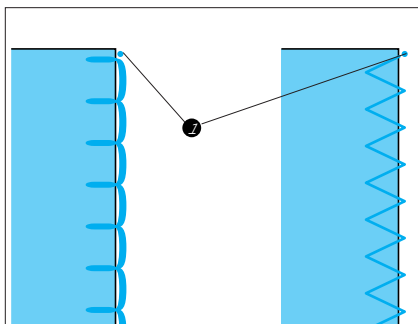

2. Finish

- ① Needle drop point

Sewing the applique around corners

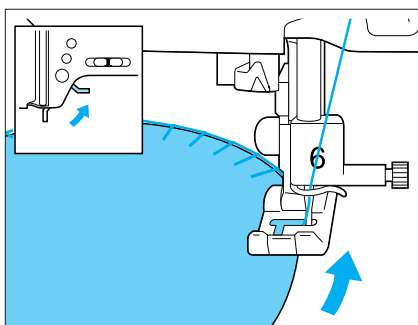

1. Stop the machine and position the needle just outside the applique.
2. Raise the presser foot and turn the fabric as needed to keep the correct needle position.

SCALLOP



Use to put a decorative trim on shirt collars and handkerchiefs.

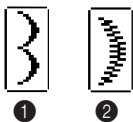

- 1 Scallop
- 2 Scallop

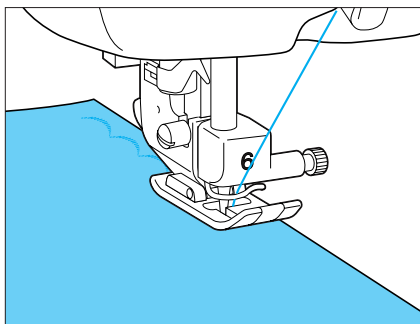

1. Attach the J foot. While sewing, take care to leave a little space between the stitches and the edge of the fabric.

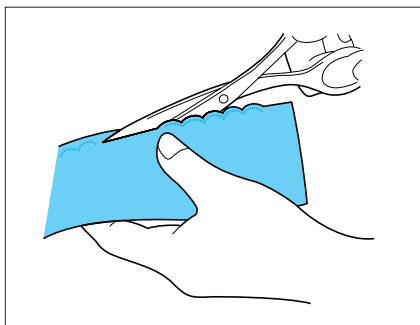

2. Carefully cut along the outsides of the stitching, taking care not to cut the threads.

Contents

Setting Up

Basic Sewing
Machine
Operation

Utility Stitches

Embroidering

Maintenance

Troubleshooting

Error
Messages

Sewing Chart

Patterns
(Programmed
In Machine)

Patterns
(Memory Card)



1

1 Patchwork stitch

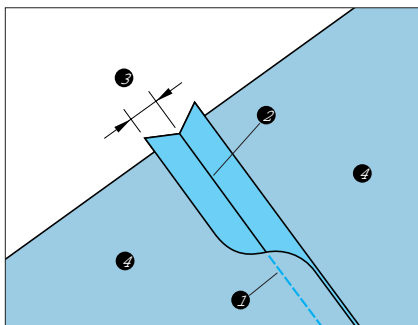

Preparations:

Press the seam open from the wrong side of the cloth.

- 1 Straight stitch
- 2 Seam allowance
- 3 1 cm (3/8")
- 4 Reverse side

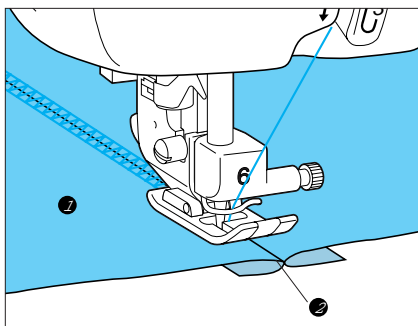

Attach the J foot. Line the presser foot up along the center of the seam and sew.

- 1 Surface
- 2 Seam

ZIPPER INSERTION (CENTERED AND SIDE APPLICATION)



Caution

Before sewing, gently turn the hand wheel to check the needle position.

Make sure that the needle does not come down onto the foot, or it could break and cause injury.



1

1 Straight

Centered application

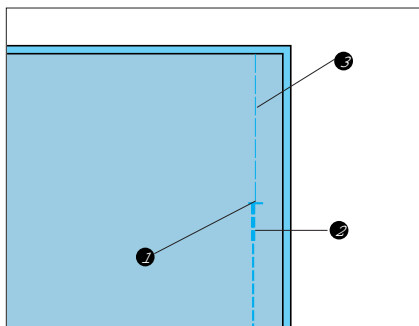

Preparations:

Attach presser foot "J" and sew straight stitches up to the crotch end. Change to a basting stitch and sew to the top of the fabric.

- 1 Crotch end
- 2 Reverse stitch
- 3 Basting stitch

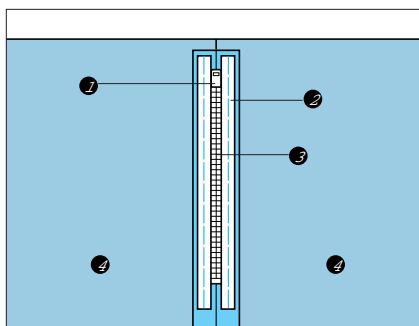

1. Press the seam allowance open and attach the zipper with a basting stitch in the middle.

- 1 Zipper slide
- 2 Basting
- 3 Zipper
- 4 Reverse side

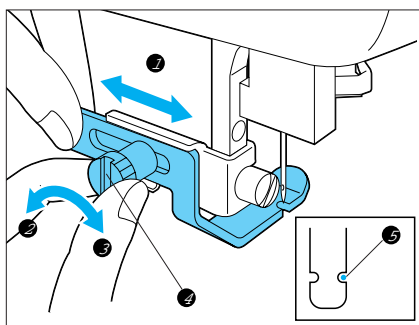

2. Attach the I foot (see p. 32). Turn the needle position adjustment knob on the back of the foot to position the foot so that the needle comes down over the right side of the foot (as shown).

(Adjust foot position so the needle is positioned over the right side of the foot when sewing the left side of the zipper, and over the left side of the foot when sewing to the right of the zipper.)

- 1 Left-Right
- 2 Loosen
- 3 Tighten
- 4 Adjustment screw
- 5 Needle drop point

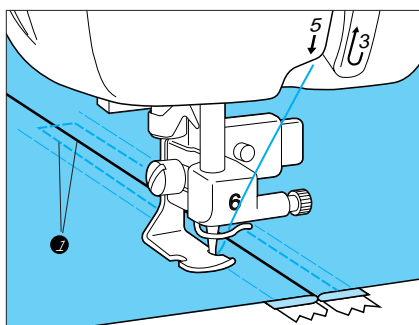

3. Sew with the machine on the right side of the fabric, and then remove basting.

- 1 0.7- 1 cm

Side application

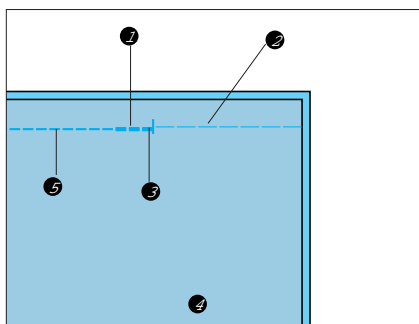

Preparations:

Attach presser foot "J" and sew straight stitches up to the crotch end. Change to a basting stitch and sew to the top of the fabric.

- ① Reverse stitch
- ② Basting stitch
- ③ Crotch end
- ④ Reverse side
- ⑤ Straight stitch

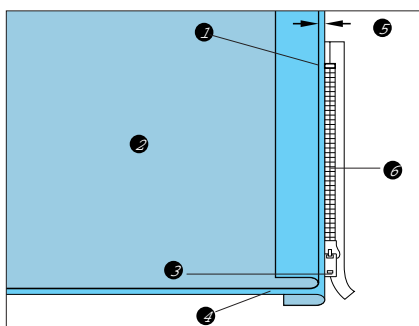

1. Press the seam allowance open and align the folded hem along the teeth of the zipper, while keeping 3 mm (1/8") for the sewing space.

- ① Crotch end (Base of zipper)
- ② Reverse side
- ③ Slider on head of zipper
- ④ Waist
- ⑤ Keep 3 mm (1/8") for sewing
- ⑥ Teeth of zipper

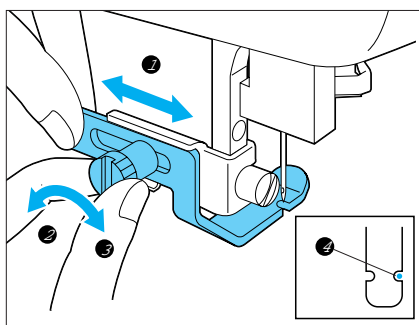

2. Attach I foot (see p. 32). Use the needle position adjustment knob on back of the foot to position the foot so the needle is positioned over the right groove of the foot as illustrated in diagram. (Adjust foot position so that needle is positioned over the left side of the foot when sewing to the right of the zipper, and to the right side of the foot when sewing to the left of the zipper.)

- ① Left-Right
- ② Loosen
- ③ Tighten
- ④ Needle drop point

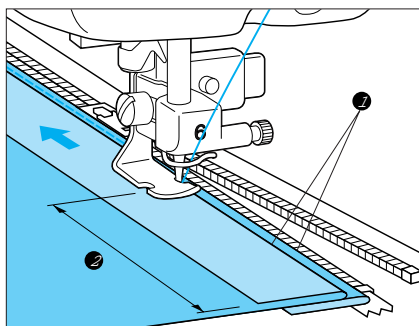

3. Sew up from the base of the opening along the center of the 0.3cm space. Stop machine when you come to about 5cm from the top of the zipper, move the zipper slide out of your way, and continue sewing to the end of the zipper.

- ① 0.3 cm
- ② 5 cm

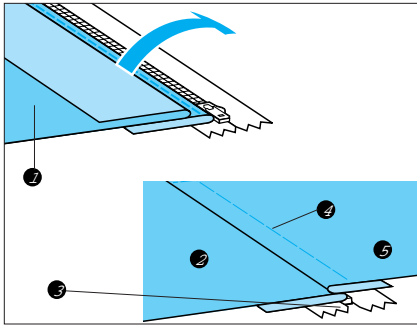

4. Close zipper. Turn fabric over to the right side and baste.

- ① Left pressed edge of zip opening (wrong side)
- ② Right pressed edge of the zip opening (wrong side)
- ③ Zipper
- ④ Basting stitch
- ⑤ Left pressed edge of zip opening (right side)

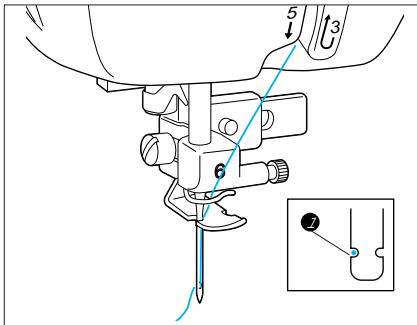

5. Position foot so needle comes down over the left side of the foot as illustrated in diagram.

- ① Needle drop point

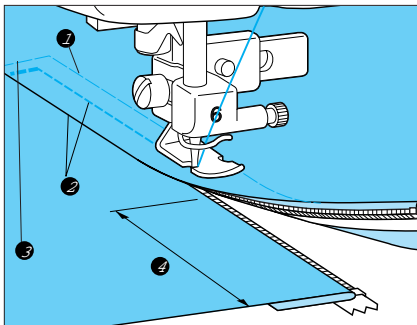

6. Sew a few stitches in reverse at the base of the opening to reinforce your stitching. Keep left edge of foot along the teeth of the zipper while sewing up the side of the zipper. When you are about 5cm from the top of the zipper, stop machine, drop needle down through fabric, remove basting, move the slide out of your way and finish sewing.

- ① Basting stitch
- ② 0.7-1 cm
- ③ Reinforcement stitches
- ④ 5 cm



Use to add a decorative touch to garments.

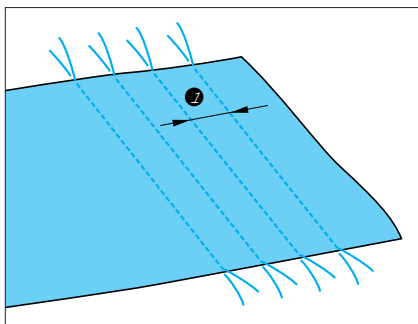

Select a straight stitch with a stitch length of 4.0 mm Reduce thread tension and sew a few rows of stitches about one centimeter apart.

- 1 About 1 cm (25/64")

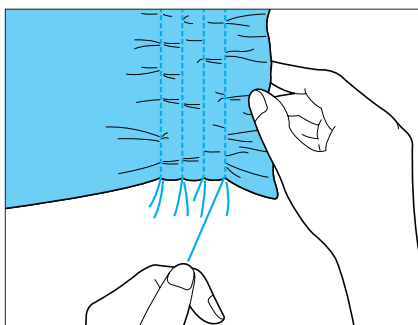

Pull the bottom of the threads to gather the cloth and iron gathers.

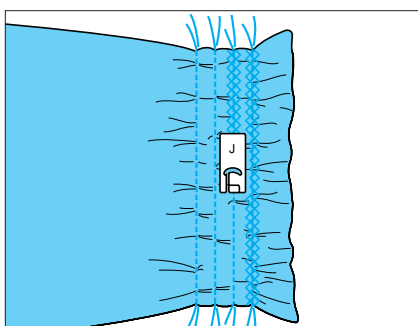

1. Attach the J foot. Sew new rows of stitches over the top of the straight stitched rows.

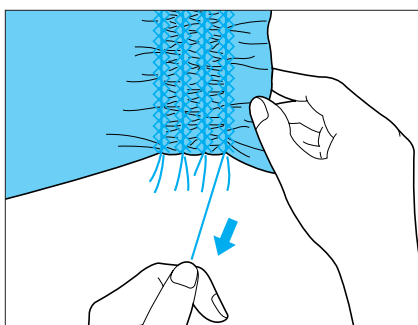

2. Pull out the threads used in the straight stitched rows.



Caution

Before starting always turn the hand wheel to check to make sure the needle isn't hitting the button. If the needle hits the button while sewing, it could break and cause injury.



1

1 Zig zag

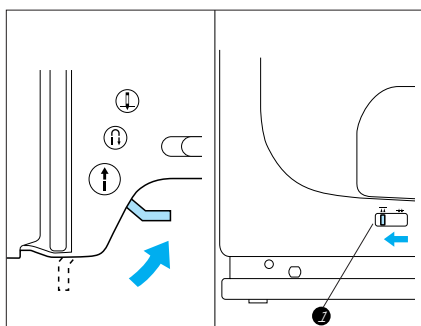

1. Raise the presser foot lever and slide the feed dog adjustment lever to the right to lower the feed dog. ()

1 Feed dog adjustment lever

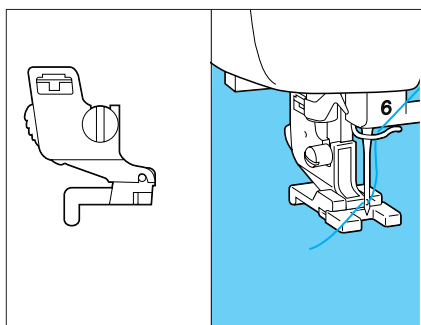
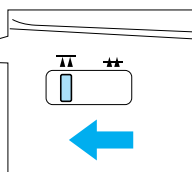

2. Attach button sew-on foot (sold separately).

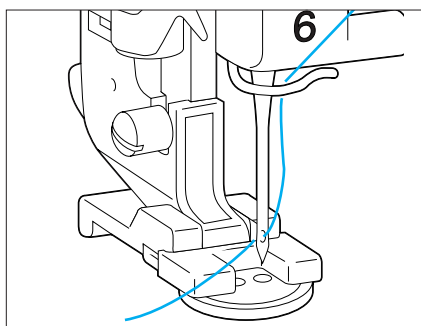

3. Select the . Place the button under the presser foot. Match up needle position with button holes. Lower the foot.

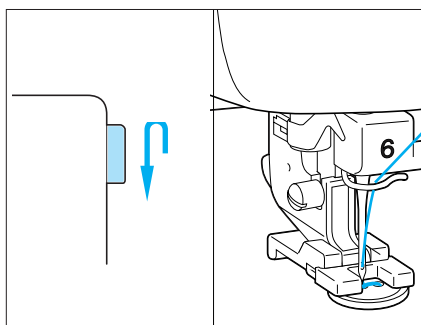

4. Turn the hand wheel slowly to make sure the needle enters the button holes without hitting the button. Sew about ten stitches and you're ready for the next button.

CAUTION

Adjust stitch width if needle doesn't pass through both button holes.

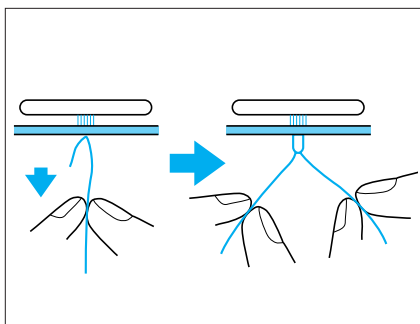

5. Once sewing is completed, return the feed dog to its original position, pull the bobbin thread at the sewing end down and pull the upper thread at the sewing end through to the reverse side of the fabric. Then tie the thread ends together and cut the threads at the sewing start.

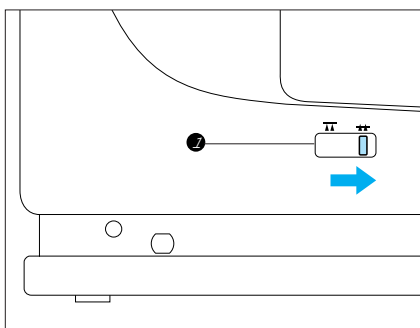

6. When you are finished attaching buttons, make sure to return the feed dogs to their original position. (**↔**)

- ① Feed dog adjustment lever

Attaching buttons with four holes

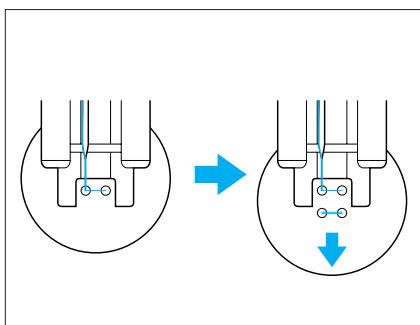

First sew the two holes which are closest to you. Once they have been sewn, raise the presser foot, move the needle to the next two holes and then sew them in the same way.



1. Embroidery unit and memory cards (optional).

CAUTION

- Do not touch the embroidery unit connectors. Doing so could cause damage to the machine.
- Do not move the sewing machine while the embroidery unit is attached. The embroidery unit could fall and cause injury.
- Do not carry embroidery unit by the carriage or apply excessive force to it, or you could cause damage.
- Keep hands and other items away from the embroidery unit carriage and embroidery hoop while they are in motion. Injury could result.

- ① Hoop holder
- ② Carriage
- ③ Connector

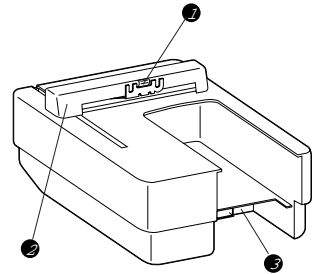

- Always store memory cards in the accessory case.
- Always turn machine off before removing the embroidery unit or memory cards.
- Please note that the small embroidery hoop (optional) will not work with certain pattern sizes and sewing positions.
- Please note that memory cards will not work with certain pattern sizes, and some memory cards are not compatible with this machine.

2. Attaching the embroidery foot “Q”

CAUTION

- Always make sure the power is off before changing feet. Injury could result if the “START/STOP” button is accidentally pushed and the machine starts running during this operation.
- Do not use the embroidery foot “Q” for anything other than embroidery.

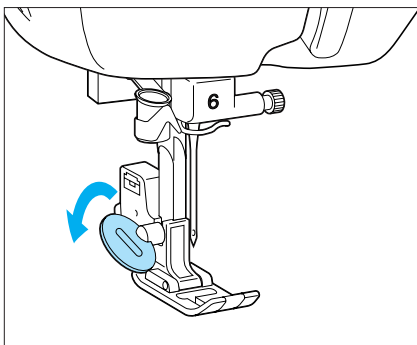

1. Raise needle with the up-needle button. Turn power off.
2. Loosen the screw on the foot holder and remove foot holder.

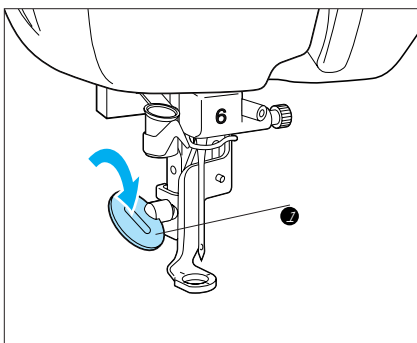

3. Attach the embroidery foot. Screw back on tightly.
 - ① Screw
 - * Make sure the needle clamp screw is also tightened.

3. Attaching the embroidery unit

CAUTION

Always make sure the power is off when attaching the embroidery unit or damage could result.

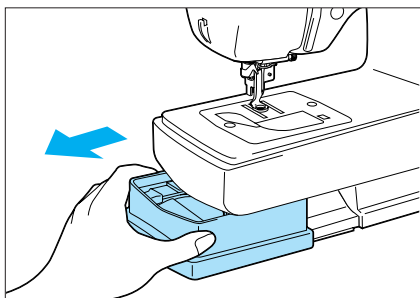

1. Turn off sewing machine.
2. Slide accessory case to the left and remove it.

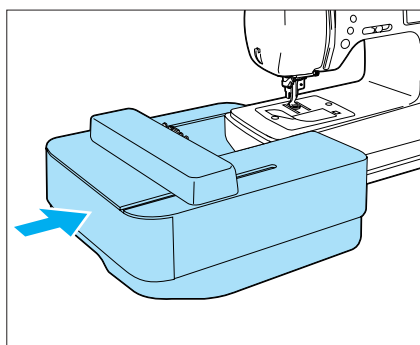



3. Remove cover of the embroidery unit. Attach unit to the machine as shown in the drawing until you hear a click sound.

CAUTION

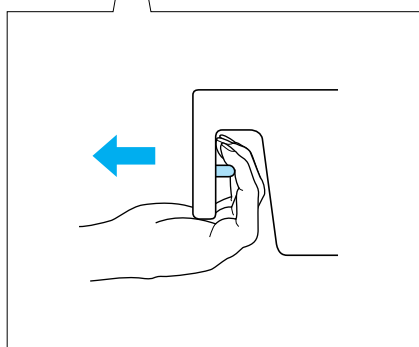
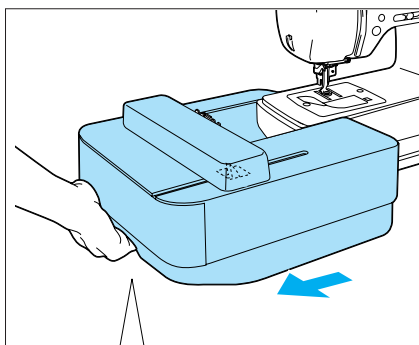
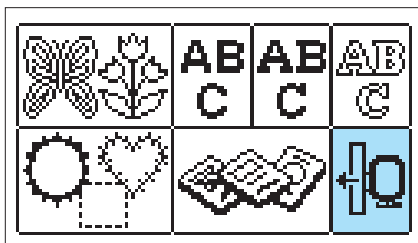

Always make sure the unit is pressed all the way into the machine to ensure accurate stitching.

Removing embroidery unit



1. Remove embroidery hoop. Push “” key. Push “” key. The carriage will move to the storage position.

CAUTION

- If the carriage is not in the storage position, you might not be able to put the cover on the embroidery unit.
- Always make sure to remove the hoop before pushing the “” key button. If you push “” key while the small hoop (sold separately) is still attached, the hoop will hit the foot and this could result in personal injury.

2. Turn the power off. Pull the embroidery unit to the left, and remove the unit while pushing the Release button.

CAUTION

Always turn the power off when removing the embroidery unit. Failure to do so could cause damage.

CHOOSING EMBROIDERY PATTERNS (PART I)

This computerized sewing machine comes with pre-programmed alphabet and patterns. You may also use optional memory cards for more designs.

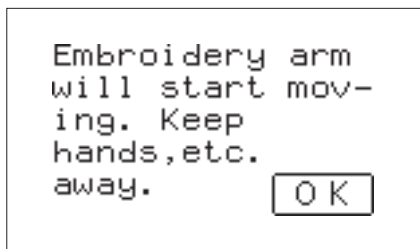

1. Turn on the machine and touch the screen. You should see the message displayed in the diagram on your screen.

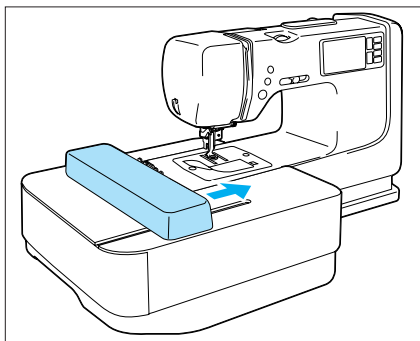

2. Press "OK" key.

CAUTION

Keep hands and other objects away from the carriage. It could cause injury. The sewing machine might make a buzzing sound if defaults are not set. Do not be alarmed. This does not mean something's broken.

Simply make sure there are no embroidery hoops attached, and turn the power on again.

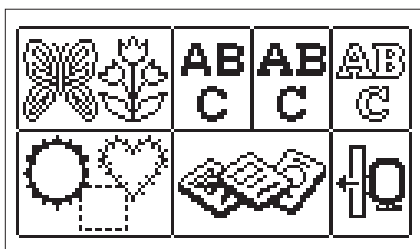

Different types of embroidery patterns will appear on the screen.



One-point patterns



Borders



Lettering



Memory card (Optional)

One-point patterns

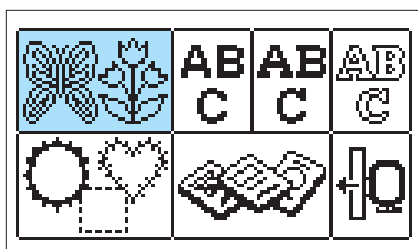

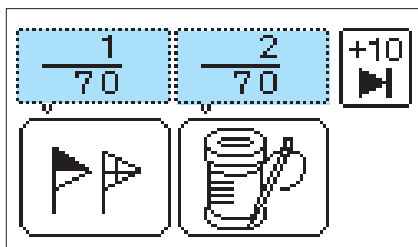

1. Push “” key.

* If you are not at the screen shown in the diagram, simply push “” key to come to this screen.

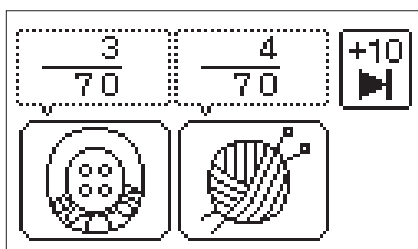

* $\frac{1}{70}$ and $\frac{2}{70}$ mean pattern number/total number of patterns *this shows the first and second patterns out of a group of 70 to choose from.



Pushing the “” key will bring you to the next screen (shown in the diagram).

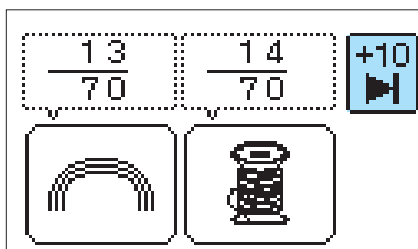

Pressing “” key will skip ten patterns forward.

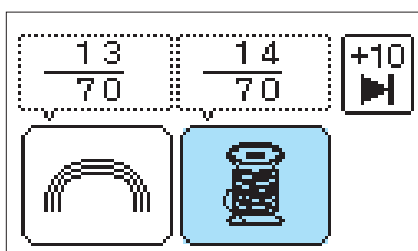

2. Touch the pattern on the screen to select the pattern you wish to embroider.

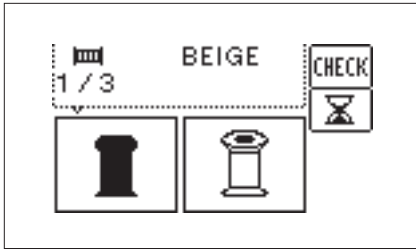

3. The Sew screen will appear.

- * Pushing “  ” key will bring you back to the previous screen.

Borders

Allows you to select a border pattern you like by choosing the shape of the border and stitch for your border.

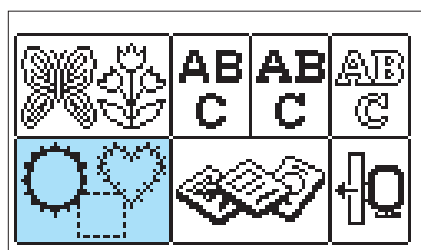

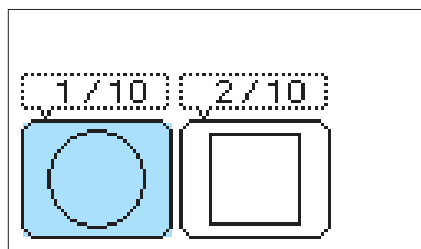

1. Push “” key.

* If you are not on the screen shown in the diagram, simply push “” key to come to this screen.



2. Choose the shape of the border you wish to embroider. Once you have selected the border shape, you will automatically be taken to the stitch selection screen.

* Pushing the “” key button will take you onto the next screen of stitches.

* Pressing the “” key will take you back to the previous screen.

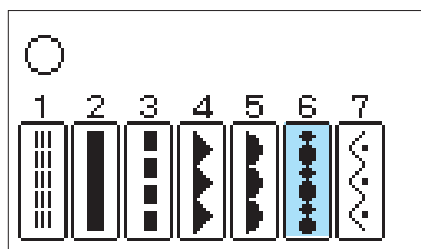

3. Choose your stitch. There is a total of 12 stitches available for you to choose from for your border.

* Push the “” key to go to the next screen of stitches.

* Press the “” key to go back to the previous screen.

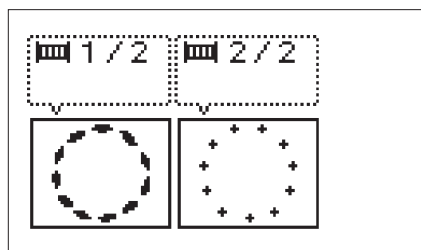

4. The Sew screen will appear.

Lettering

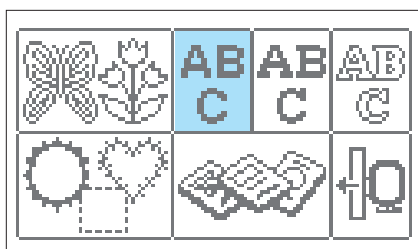



Press “” key.

- * If you are not on the screen shown in the diagram, simply push “” key to come to this screen.

Example: For practice, try the word "BUS":

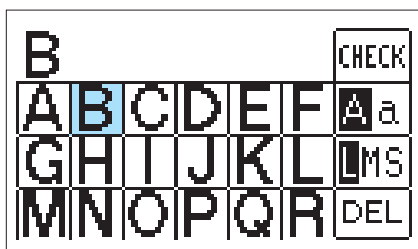
1. Press “” key. The letter “B” should appear at the top of your screen as shown in the diagram.



2. Press the “” key to get to the next screen of letters.

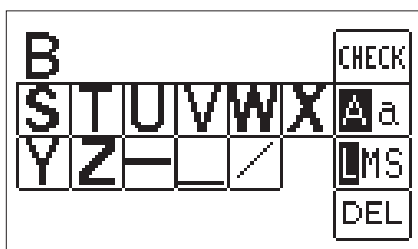

3. Press “” key. Now the "BU" should appear at the top of your screen.

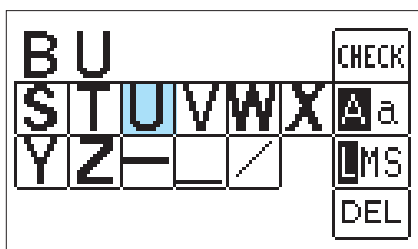

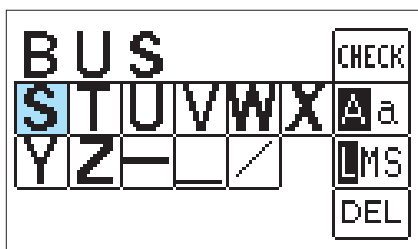

4. Press “” key. The entire word "BUS" should appear at the top of your screen.

It's that easy.

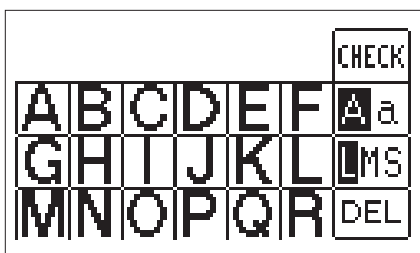

Numerals and punctuation



Pushing the “  ” key will take you to the Punctuation and Number screens.

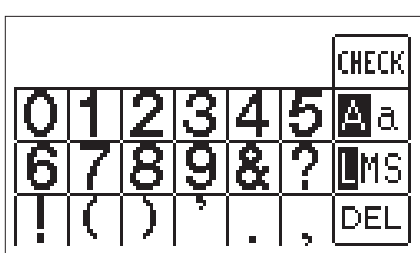
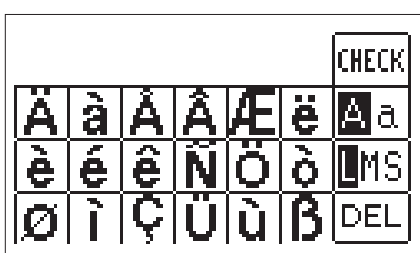
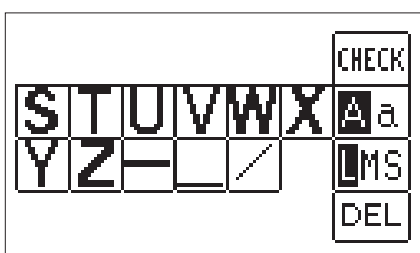

Lower and upper case letters

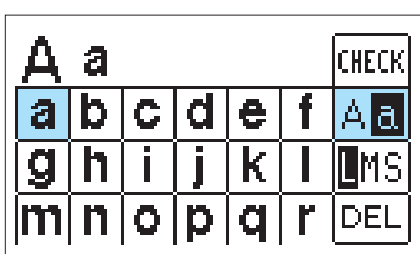

The “  ” key button allows you to alternate between upper and lower case lettering.

Selecting patterns from a memory card

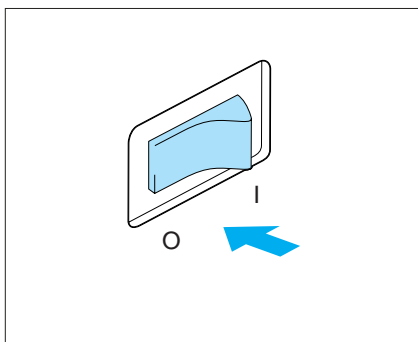

1. Turn off the power.

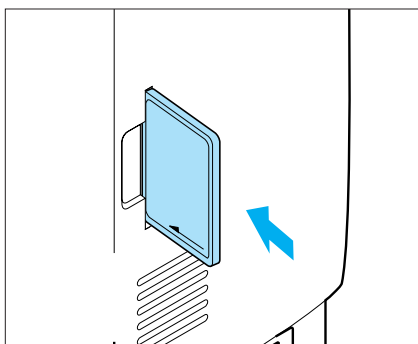

2. Insert the memory card you wish to use into the card slot, which is located on the right side of the sewing machine. The arrow on card should be facing you and pointing to the left, into the machine. Push the card straight in so it goes all the way in.

CAUTION

Do not attempt to force the card into the machine in any direction other than the direction the arrow is pointing. Attempting to do so could cause damage.

3. See pages 65-70 for directions on choosing stitches and embroidery patterns.

CHOOSING EMBROIDERY PATTERNS (PART II)

If you accidentally choose the wrong design

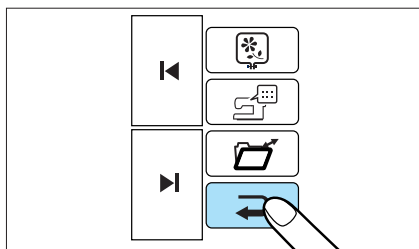

1. Press the “  ” key to go back to the previous screen.

If you choose the wrong character

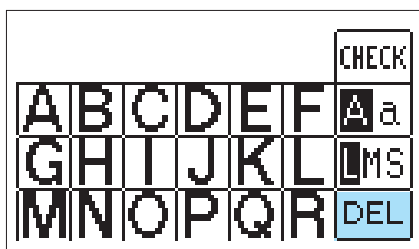

Press “  ” key. Each time you press delete it will delete the last character on the top of the screen.

To change size

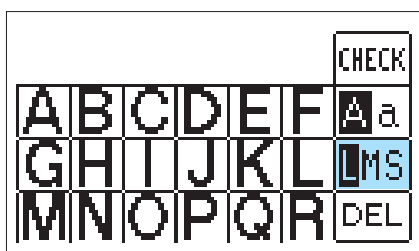

Pressing the “  ” key (Large/Medium/Small) button until the desired size is highlighted.

To make words

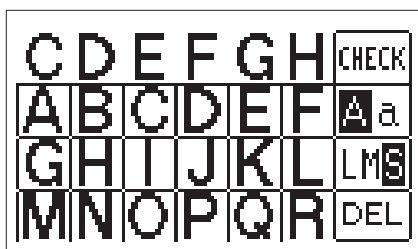

Example: For practice, try entering the characters "ABCDEFGH"

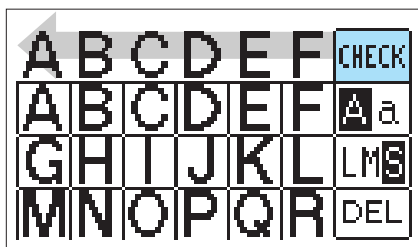

1. Press "CHECK" key. The letters will scroll across your screen to the left starting with the first letter selected.

* The screen only scrolls if the letters will not all fit in the screen.

EMBROIDERING

Embroidering attractive finishes

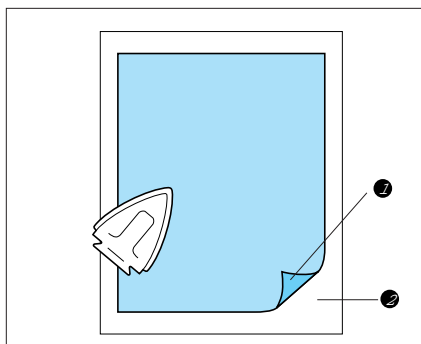

Stabilizers

- Use stabilizers to create beautiful embroidery without puckering or poor stitch conformation. Iron-on Stabilizers are recommended especially for lightweight fabrics and/or stretchable fabrics. For certain fabrics you might wish to use a thick stabilizer or two layers of stabilizer.

- 1 Stabilizer
- 2 Fabric

* We recommend Brother Iron-on stabilizers that can be torn off after you're finished.

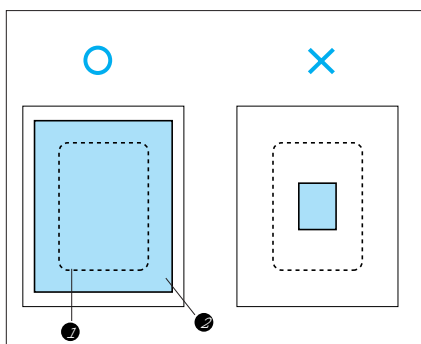

- Use a stabilizer that is larger than the size of the hoop so that the entire stabilizer can be hooped with the cloth as shown in the diagram. This is to prevent the fabric from sagging.

- 1 Size of embroidery hoop
- 2 Stabilizers

- When embroidering heavyweight fabrics or fabrics that cannot be ironed, you can use the stabilizers by placing them under the cloth without actually attaching it.

THREAD and NEEDLE

THREAD	Upper thread - embroidery thread #50 Bobbin thread - embroidery bobbin thread (X81164-001) Perfect needlework cannot be guaranteed with the use of other threads.
NEEDLE	Home sewing machine needle 75/11 Do not use ballpoint needles.

* Use Brother embroidering thread (X81164-001) for the bobbin thread.

Types of embroidery frames

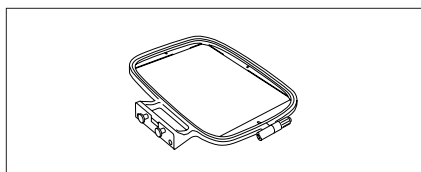

Medium frame

- 1 10 cm (H) × 10 cm (W)

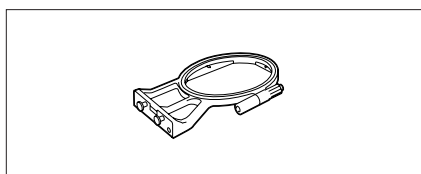

Small frame (Optional)

- 2 2 cm (H) × 6 cm (W) (for embroidering initials)

CAUTION

Depending on the size of the pattern and the position of the pattern to be embroidered, it may not be possible to use the small frames. When using this frame, be sure to check the layout screen display (refer to page 83) before starting to embroider any patterns. If the frame are used by mistake, the presser foot may strike the frame, which could cause injury.

Setting the fabric into the embroidery frame

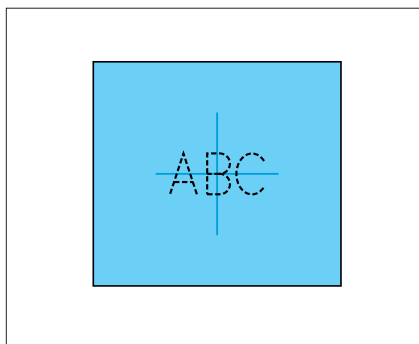

1. Mark the fabric using a chalk pen or fabric marking pen to indicate the embroidering position.

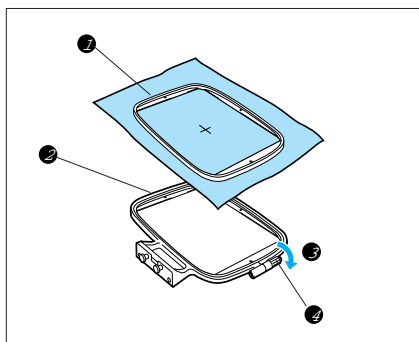

2. Loosen the adjusting screw and separate the inner and outer frames. Lay the fabric on top of the outer frame and secure it between the inner and outer frame, and tighten the adjusting screw just enough to secure the fabric. Gently remove the fabric from the frame without loosening the adjusting screw.

* Be sure to align the mark on the inner frame with the (Δ) mark on the outer frame.

- ① Inner frame
- ② Outer frame
- ③ Loosen
- ④ Adjusting screw

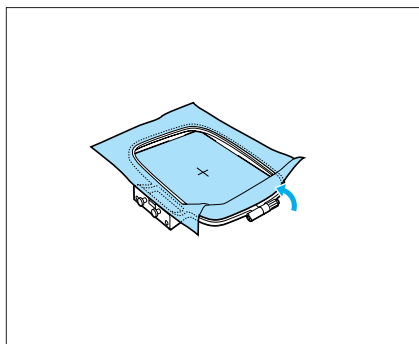

3. Tighten screw of outer hoop to hold fabric and inner hoop in place.
Remove fabric and inner hoop.

(For best results lay the outer frame on a flat table surface and lay the fabric on top of it.)

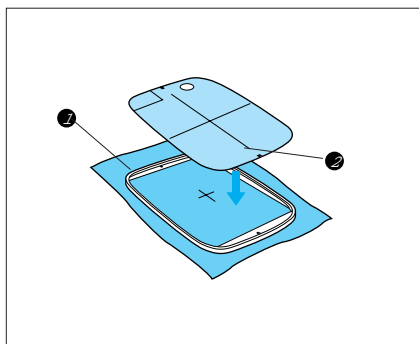

4. Place the embroidery sheet into the inner frame, while matching lines on the sheet with mark on fabric.

- ① Inner frame
- ② Standard line

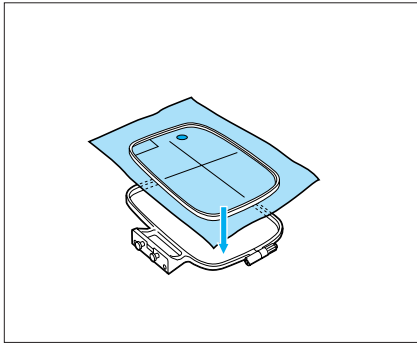

5. Press down into the outer frame so that the mark doesn't move out of place.

- ① Outer frame
- ② Inner frame
- ③ Surface of fabric

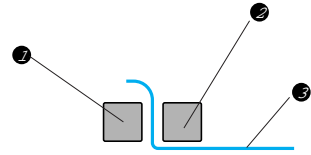

* Press down firmly until the outer frame and inner frame are at the same height.

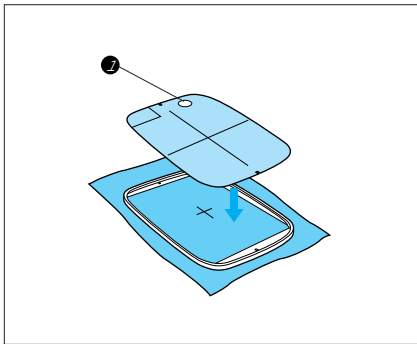

6. Remove the embroidery sheet before starting to embroider.

- ① Finger hole for removing grid

Fitting the embroidery frame to the embroidery unit

CAUTION

Be sure to wait until the embroidery unit has finished initializing before fitting the embroidery frame. (Refer to page 65.)

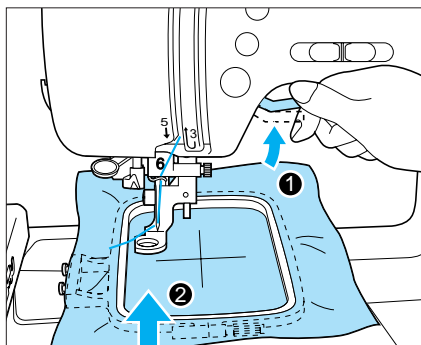

1. Raise the presser foot to its highest position. Then pass the embroidery frame under the presser foot with the mounting bracket on the left side and the fabric right side up.

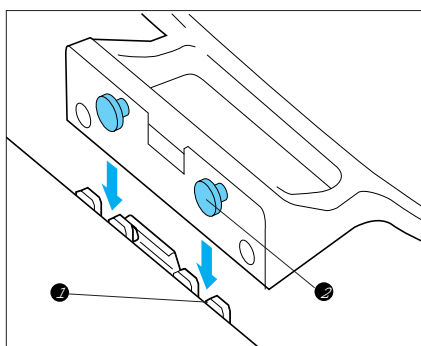

2. Align the two pins on the embroidery unit frame holder with the mounting bracket on the frame, and then press the frame into the embroidery unit frame holder until a click is heard.

CAUTION

Always make sure to attach the hoop by both pins. If the hoop is not firmly attached, it could mess up your stitching.

- ① Embroidery arm frame holder
- ② Pins

Removing the embroidery frame

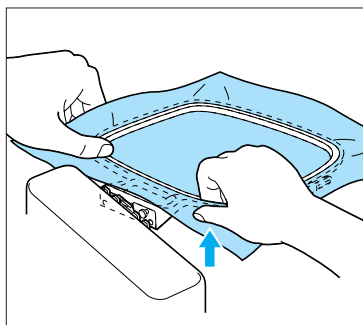

1. While holding the frame with both hands, pull the front of the hoop up to lift it out of the front pin.

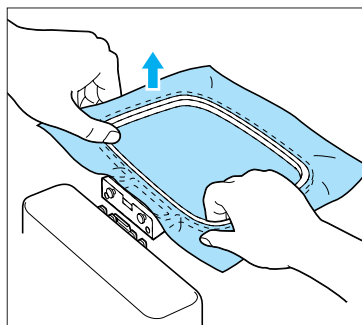

2. Then pull the back of the hoop up to lift it out of the back pin.

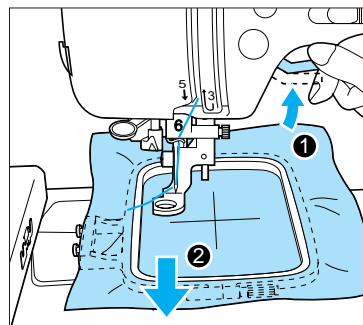

3. Raise the presser foot lever, then pull frame out from under foot.

Embroidering

CAUTION

- When sewing embroidery, Brother embroidering thread (X81164-001) must be used for the bobbin thread.
- Check bobbin thread before beginning to sew. If you embroider when the bobbin thread is low, the thread could tangle up or other problems could result.
- If you are using the embroidery unit, the foot controller cannot be used at this time.

Example :

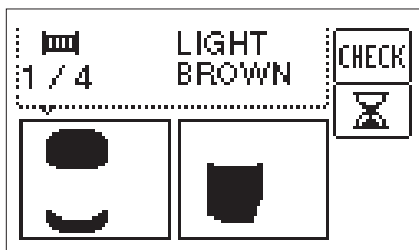

1. Select the desired pattern.
The order of sewing for each part will be displayed.
 - *  1/4 indicates that the picture displayed to the left is for the first color to be stitched of a four-color design.
 - * The color displayed above each pattern is suggested color to use.
 - Some parts may not have a color displayed above them; you can sew these parts with any color you like.
 - Refer to Color screen.

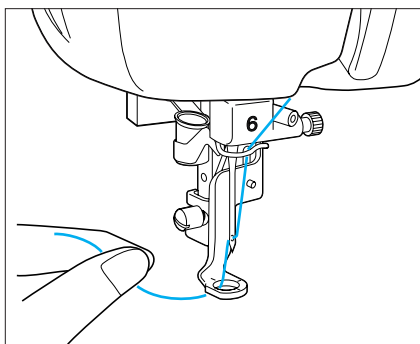

2. Thread the needle for the first color and pass it through embroidery foot "Q". Hold this thread in your left hand while leaving a certain amount of slack in the thread.

CAUTION

Be sure to raise the presser foot lever before threading the needle.

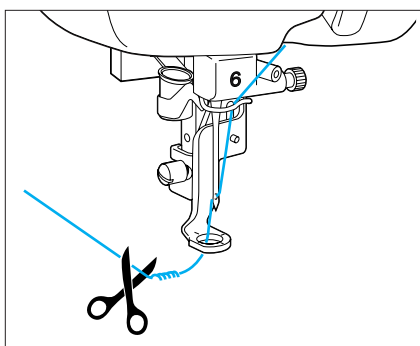

3. Lower presser foot lever and start embroidering. After 5 to 6 stitches have been sewn, stop the sewing machine and cut off any surplus thread from the end of the seam.

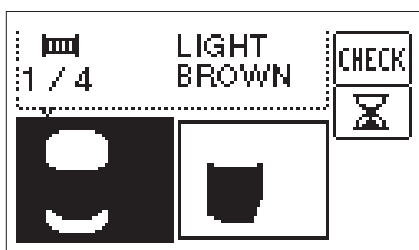

4. Start sewing again. The machine will sew the first color, then stop automatically. (When it stops sewing, the screen automatically scrolls to the left to display the next color to be sewed on the left side of the screen.)

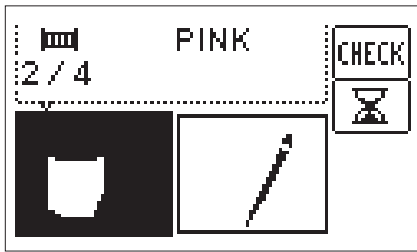

5. Change the thread to the next color and start sewing again. The machine will continue to stop for thread changes.

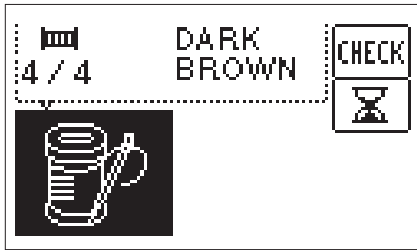

6. Continue changing threads and starting the machine through the third and fourth colors. After it has sewn the fourth and last color, it will stop automatically. (The screen will automatically return to the first screen.)

7. Trim excess threads.

Embroidering order for pattern parts

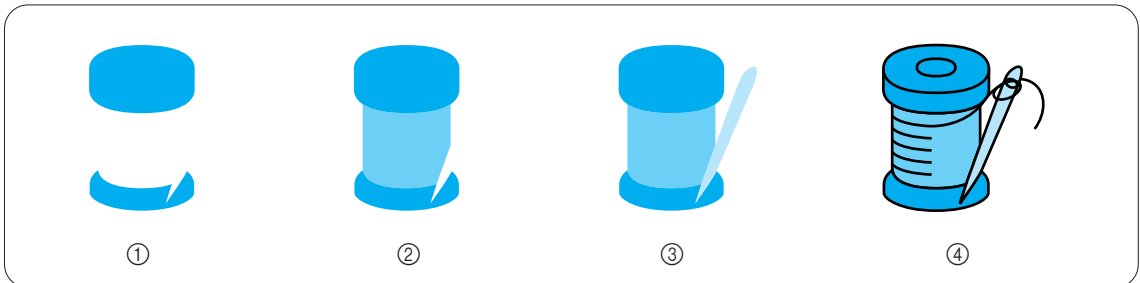

THREAD TENSION

Set thread tension according to the fabric you are using with the tension dial.

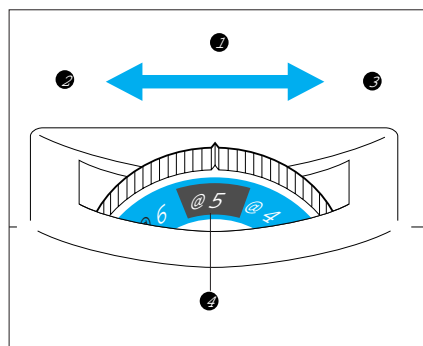

When doing machine embroidery, the tension dial should be set somewhere between 2-6.

- ① Upper thread tension setting
- ② Loose (Decrease thread tension)
- ③ Tight (Increase thread tension)
- ④ Upper thread tension dial

* Use the following chart as a guide for tension dial settings.

Fabric	Dial Setting
Heavyweight fabrics (denim, fleece, felt)	5
Medium and lightweight fabrics (broadcloth, jersey)	(3~4)

* If the stitches appear loose, turn the tension up one notch and re sew.

* When stitching one-point patterns on medium and lightweight fabrics, you can do better work if you reduce the tension by a half notch when sewing the outline.

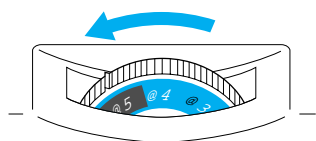
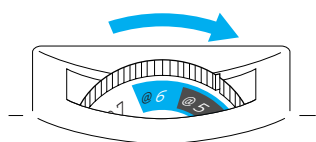

Turn the dial to the right to increase tension.

Turn the dial to the left to reduce tension.

* If the tension dial is set extremely low, the machine may stop stitching during sewing. This is not a sign that anything's broken. It only indicates that your tension is set extremely low. Simply increase the tension slightly to continue sewing.

Correct thread tension

Surface of the fabric is about one-third of the total width.

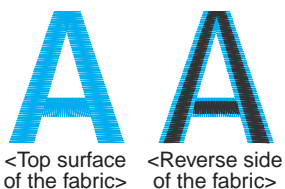

Poor stitch tension can result in poor stitch conformation, puckered fabric and thread breakage.

If upper thread tension is too tight

The lower thread will be visible on top.

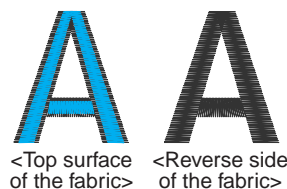

Decrease the upper thread tension.

If upper thread tension is too loose

The upper thread will be loose

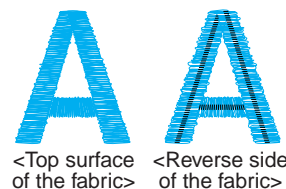

Increase the upper thread tension.

CHECKING THREAD COLORS AND TIME REQUIRED

Checking thread colors

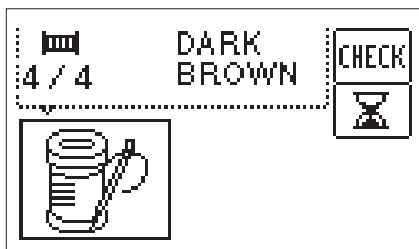
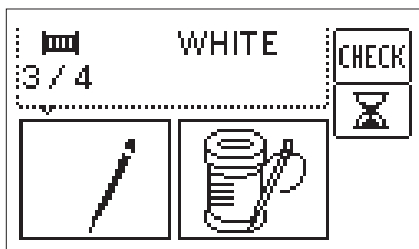
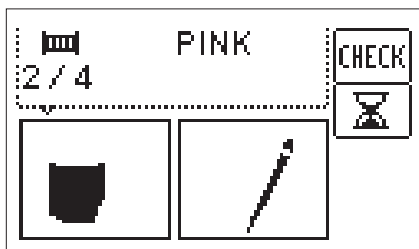
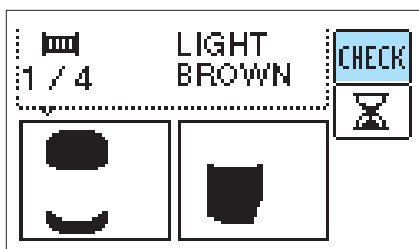

Press "CHECK" key. Colored sections will move one after another to the left, from the first colored section to be stitched to last.

* Automatically scrolls at a rate of one screen per .3 seconds.

After scrolling through all color changes, you will be taken back to the first screen.

Checking time required to complete a pattern

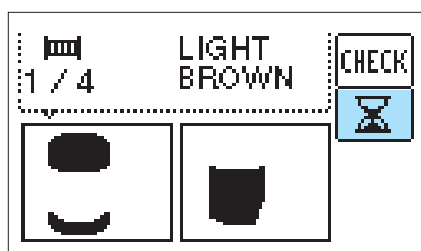

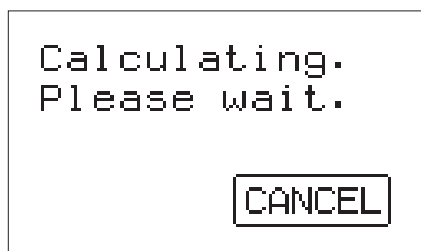

Press “” key.

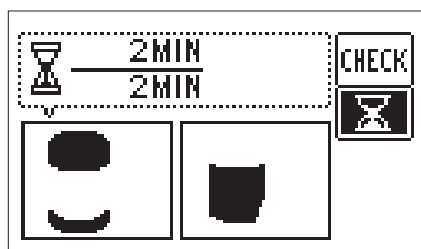

The amount of time required for the pattern will be calculated and displayed on the screen.

* Press “” key to return to previous screen.





“ $\frac{2MIN}{2MIN}$ ” means time remaining/time required

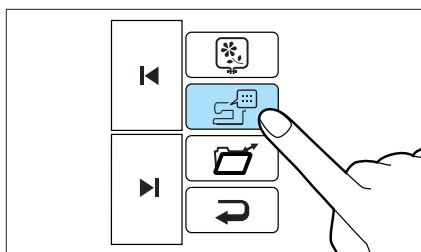

The machine's calculations do not include the amount of time it takes you to change threads 2 minutes/2 minutes

* Press “” key to return to the color screen.

CHOOSING EMBROIDERY PLACEMENT



1. Press “  ” key to go to the edit screen.

* You cannot choose or delete patterns from the “  ” key screen. If you wish to do so, press  to go back to the previous screen.

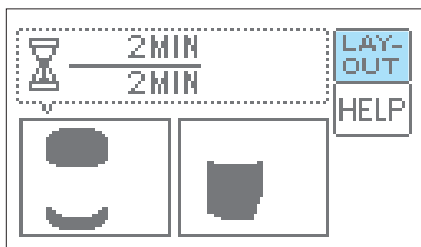

2. Press “  ” key.

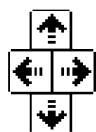
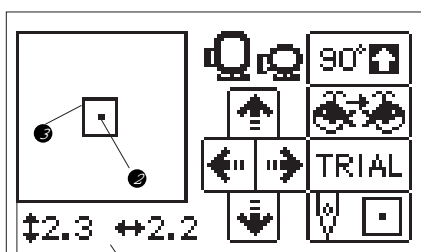

Press the directional arrows to set needlework placement.



Press to rotate the pattern in 90° increments. (The pattern will rotate in the direction of the arrow.)



Press this to flip the design to the left or right (mirror image).

* Not applicable to all patterns.





Press to move the embroidery hoop so you may check your work.



Press to move placement of the needle from the center to the lower left side of the work.



Displays the embroidery hoops that can be used for the selected pattern.

 **Small hoop (Optional)**
 **Regular hoop**

- ① Shows size of the pattern.
- ② Shows current needle position.
- ③ Shows the position and area to be stitched.
- ④ Displays the entire area that can be stitched (10×10 cm).

Moving the embroidery location

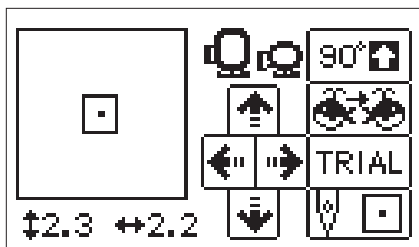

Use directional arrows to change the placement of pattern on the fabric.

CAUTION

Do not lower the needle while the hoop is in motion. Doing so could cause broken needles and possible injury.

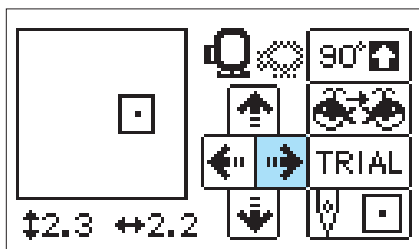

Checking the embroidering area

TRIAL

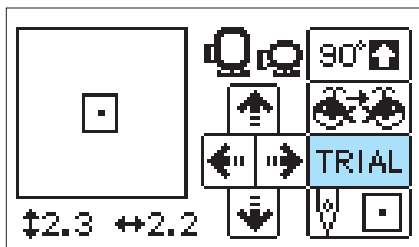

Press “ **TRIAL** ” key to move the hoop so you can check your work. Make sure to watch it closely to make sure it returns to the exact same position when you're done checking your work.

CAUTION

Do not lower the needle while the hoop is in motion. Doing so could cause broken needles and possible injury.

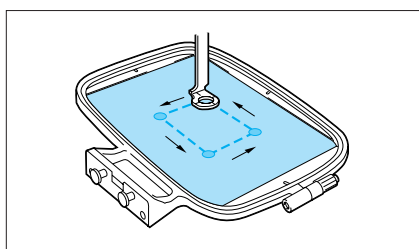

Embroidering from a specific starting point

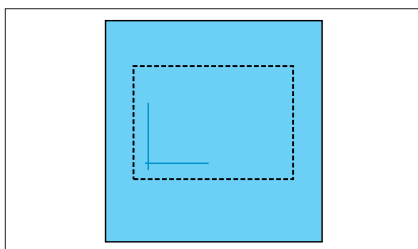

1. Mark the point to begin embroidering as shown in the diagram.

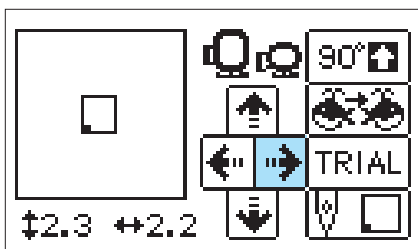

2. Press “” key. The embroidery hoop will move to place the needle above the lower left corner of the pattern.

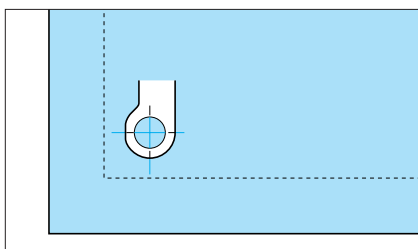

3. Use the directional arrows to match the foot up with the mark where you wish your design to be placed.

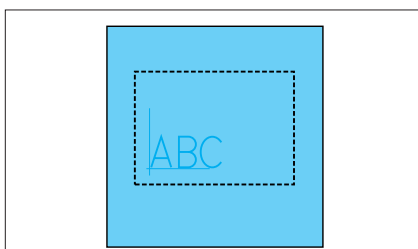

4. Sew the pattern.

ROTATING AND MIRRORING PATTERNS

Rotating patterns 90° ↻

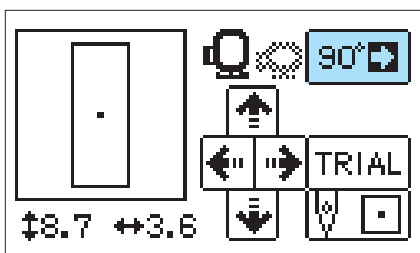

1. Press “ 90° ↻ ” key. Each time you press it, your design will rotate in 90° increments to the right. The arrow indicates direction.

CAUTION
When rotating the pattern, make sure you are using a hoop that can do this. Using a hoop other than what is indicated on the screen could cause the needle to hit the frame and result in injury.

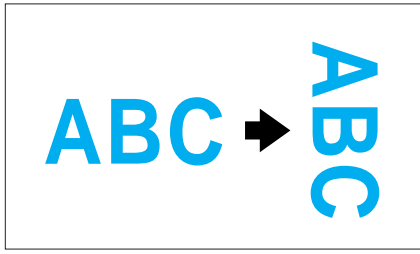

Mirroring patterns ↻

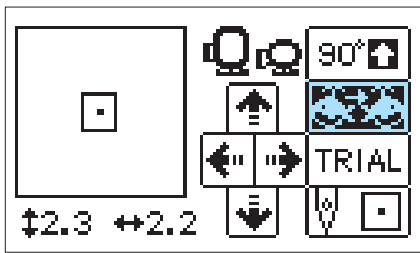

Press “ ↻ ” key to “ ↻ ” key it as shown.

- * When “ ↻ ” key is highlighted, it indicates that the design has been mirrored.
- * Not applicable to all patterns.

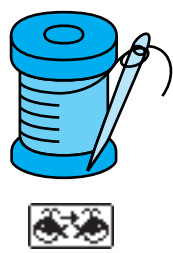



CHANGING SIZE AND STITCH DENSITY OF CHARACTERS AND BORDERS

To change size

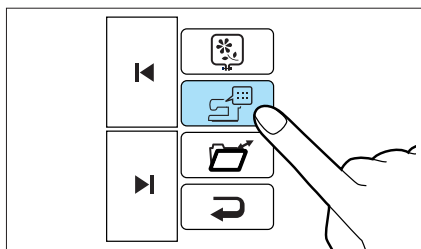
SIZE



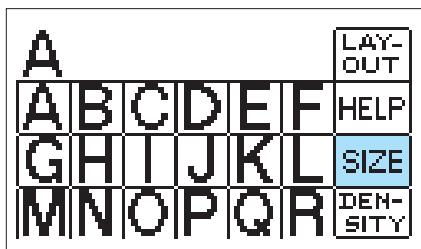

1. Press “” key to go to the edit screen.

* You cannot select or delete a pattern from the “” key screen. If you wish to do so, push “” key to return to the previous screen.

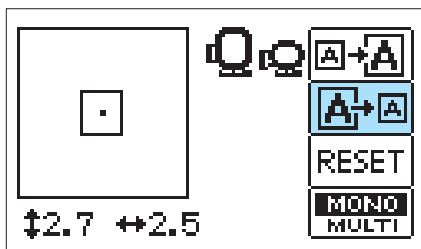

2. Press “**SIZE**” key.



3. Press “” key to make the pattern larger or “” key to make it smaller.

* Some border patterns can be enlarged more than others.
* Press “**RESET**” key to return border to its original size.
* Press “” key to return to the previous screen.

To change stitch density (limited to certain alphabets and borders)

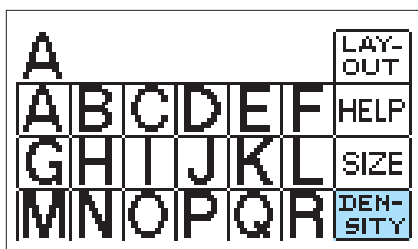

1. Press “” key, then press “**DENSITY**” key.

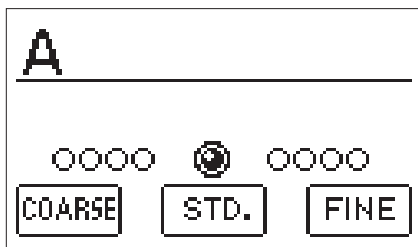

2. Press “**FINE**” key for a finer stitch density, or “**COARSE**” key for a coarser stitch density.

<Fine density> <Normal density> <Coarse density>

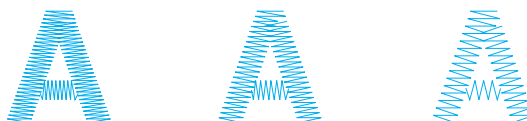



* Press “**STD.**” key to return to normal stitch density.

* Press “” key to go back to the previous screen.

Multi-colored lettering

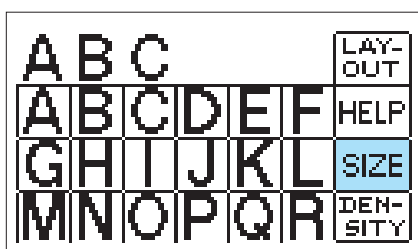
**MONO
MULTI**



1. Press “” key, then press “**SIZE**” key.

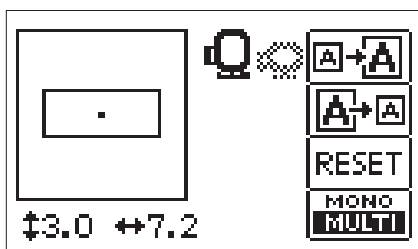

2. Press “**MONO MULTI**” key. The machine will automatically stop after each character is sewn so that you can change threads for each character.

* Press “**MONO MULTI**” key a second time to return to regular single colored lettering.

* Press “” key to return to the previous screen.

IF THE THREAD BREAKS DURING EMBROIDERY

If the upper thread breaks

HELP

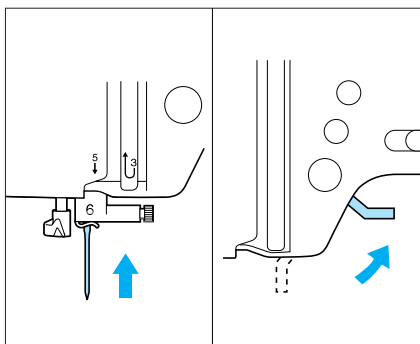

1. Stop the machine, raise the needle and foot, and rethread the machine.
 - If the bobbin thread breaks
 - ① Cut the upper thread, raise needle and foot, and remove hoop.
 - ② Reset the bobbin thread, then reattach hoop.

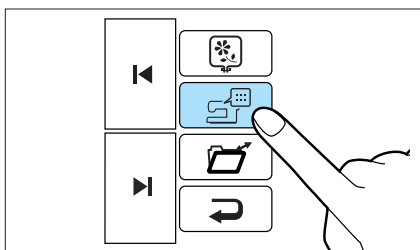

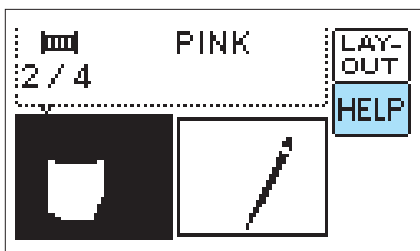

2. Press "  " key.

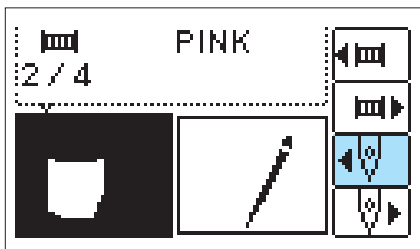

3. Press "  " key.



4. Press "  " key to go back a few stitches before the thread broke.

* If unable to return to the point the thread broke, Press "  " key to go to first stitch of that color and then "  " key to advance near the point of the thread breakage.



Returns to the first stitch of the color without sewing.



Advances to the first stitch of the next color without sewing.



Goes back one stitch at a time. Hold the button down to change from 6 stitches at a time to 9 stitches at a time.



Goes forward one stitch at a time. Hold the button down to change from 6 stitches at a time to 9 stitches at a time.

Contents

Setting Up

Basic Sewing
Machine
Operation

Utility Stitches

Embroidering

Maintenance

Troubleshooting

Error
Messages



Sewing Chart

Patterns
(Programmed
In Machine)

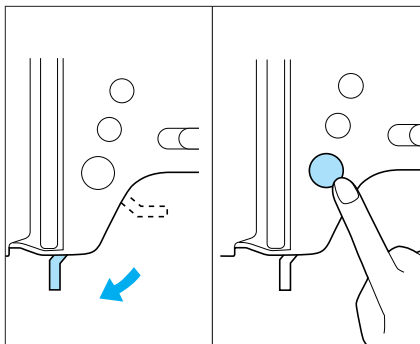
Patterns
(Memory Card)



5. Lower the presser foot and push “START/STOP” button.

- The machine might not start sewing right away after pressing “” key or “” key . This is nothing to be alarmed about. Just push “START/STOP” button again.

When starting over from the beginning

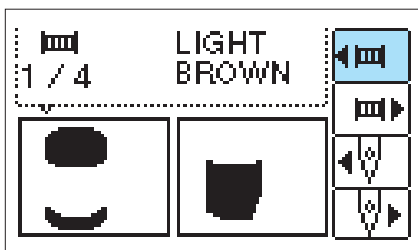

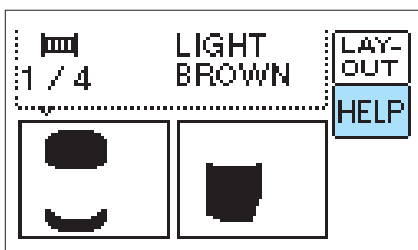

1. Press “” key to return to the first color and place the needle over the starting position.
2. Lower the presser foot and push start.

Continuing after the power shuts off



Example

Continuing from a position within the second color.

1. Select the pattern, press “” key and then press “HELP” key.
2. Press “” key to go to the first stitch of the second color.
3. Press “” key to advance to a position a few stitches before you left off.
4. Lower the foot and press start.

Note

If you change the pattern placement on the layout screen and continue sewing, first move the position on the layout screen by the same degree before carrying out the above procedure.

EMBROIDERY APPLICATIONS

Combining characters to form words

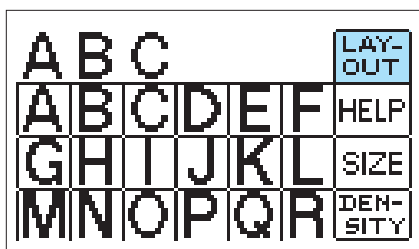

1. Enter "ABC", press "  " key, and then press "  " key.

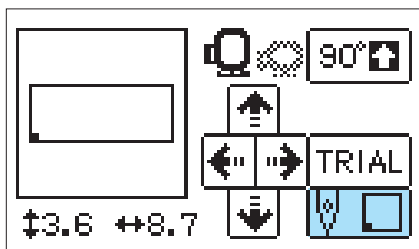

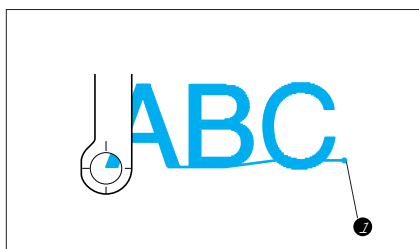

2. Press "  " key to move the position of the needle over the fabric from the center to the lower left corner.



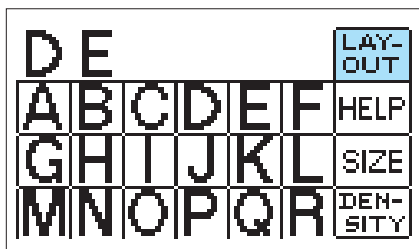

3. Press "START/STOP" button. After "ABC" has been stitched, move the fabric so the foot is in position to stitch "DE".

① Ending position



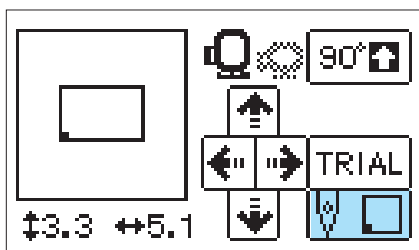



4. Enter "DE" and press "  " key.

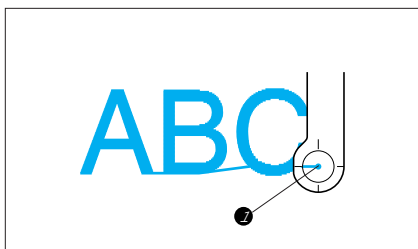

5. Press "  " key again to move the position of the needle from the center of the fabric to the lower left corner.



6. Use “   ” key to move the foot so the needle will make its first stitch at the point it ended off "ABC".

- ① Needle position of last stitch



7. Press “START/STOP” button.

Outline Embroidery

Try something different by stitching only the outline of the pattern.

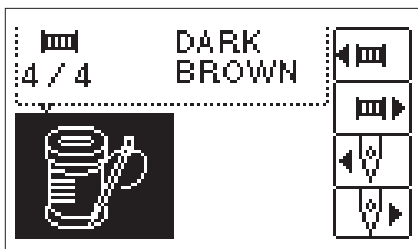

1. Press “” key to display the outline of the pattern on your screen.

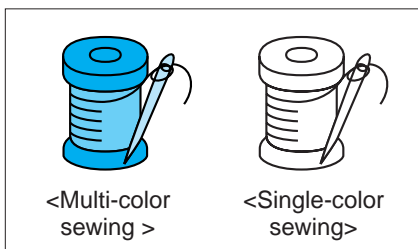

2. Lower the presser foot and begin stitching.

Embroidering appliques (using a frame pattern)

You can use frame patterns with the same shape and size to sew appliques.

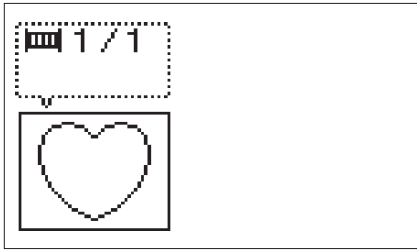

1. Select the frame shape to be embroidered and select the “” stitch. Embroider onto the applique material. Remove the fabric from the embroidery frame.

Cut neatly around the outside of the shape made by the stitches.

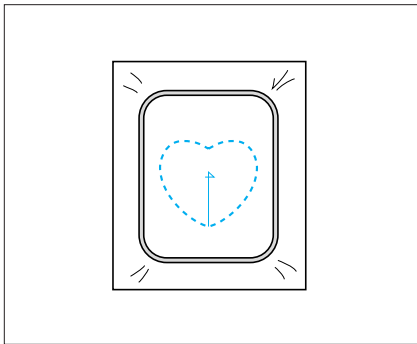
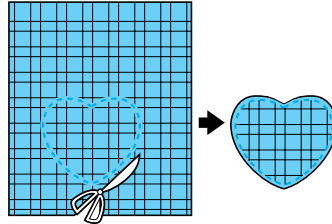

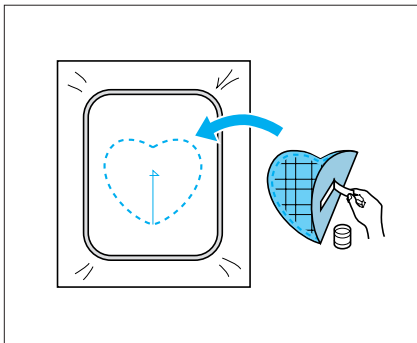

2. Embroider a base fabric in the same way using the same frame pattern shape and the stitch as in step 1.

* Do not change pattern size or position.

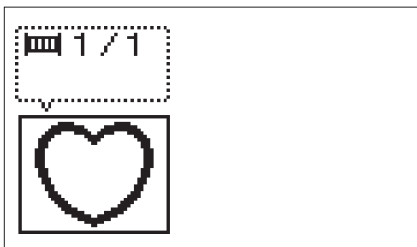

3. Apply a thin layer of fabric glue to the rear of the applique material which is created in step 1, and then attach it to the base fabric so that it follows the frame shape just stitched.



4. Without changing the frame shape or size, select the “” stitch, and use it to embroider the applique material onto the project.

* Do not change size and sewing position.

- 1 Applique

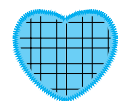
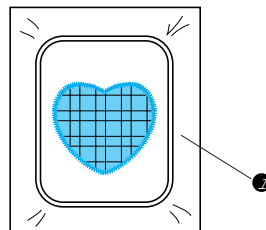

Finished applique on the project

Embroidering onto small pieces of fabric or onto corners

Use a stabilizer to support the fabric while stitching. When finished, remove the stabilizer carefully. We recommend Brother stabilizers designed especially for use with our machines.

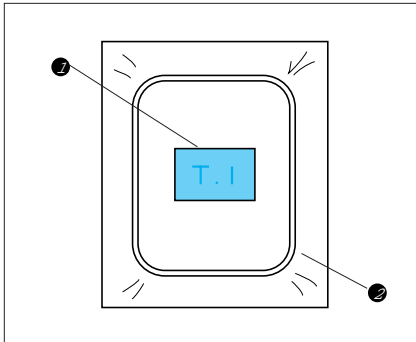

• Example A

- 1 Iron on to attach to fabric (If you don't wish to use an iron, you may attach by basting).
- 2 Stabilizer

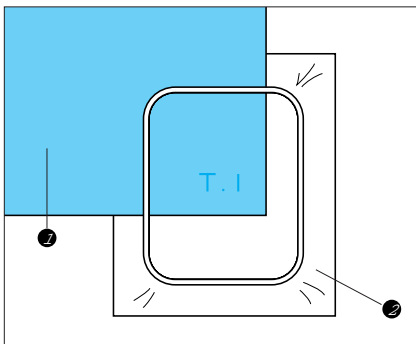

• Example B

- 1 Fabric
- 2 Stabilizer

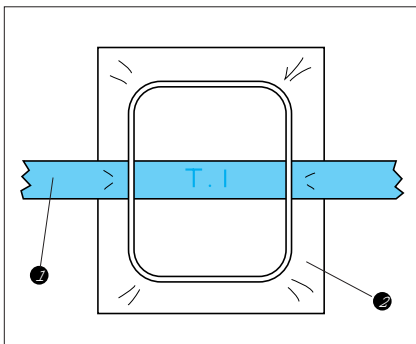

• Example C

- 1 Ribbon (Secure with double-sided tape)
- 2 Stabilizer

MEMORY

You can save patterns of linked characters and restore them when you wish to use them. (See page 5 for directions on saving designs)

Saving groups of characters

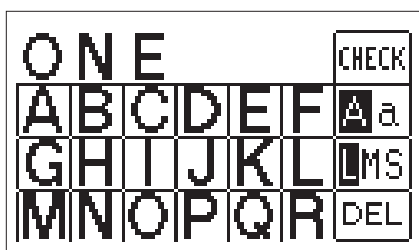



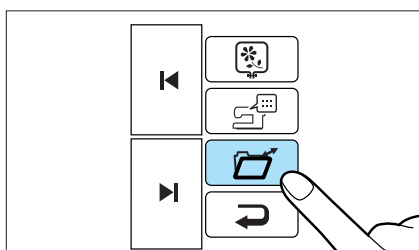

For example, to save the word “one” on page one.

1. Enter the letters “ONE”.

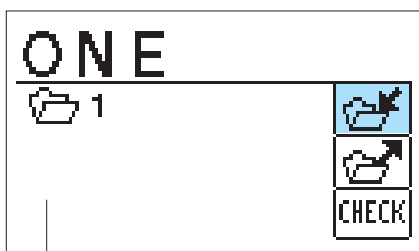

2. Press “” key.



3. Use “” and “” keys to select a page to store your design and press “” key.

* If you try to save pattern on a page that already has something saved on it, the old pattern will be deleted to make room for the new one.

* Do not shut off the power while saving a pattern.

❶ If an embroidery design is already stored in memory at the chosen position, it will be displayed on your screen.



4. Pattern has been saved.

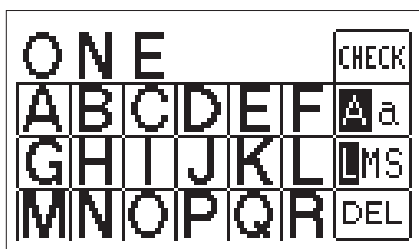

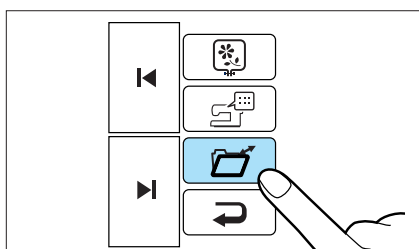

Restoring saved designs

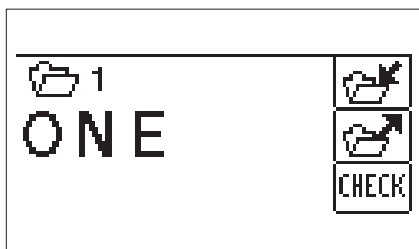

For example, to restore the word "GIRL".

1. Press “  ” key.



2. Press “  ” key.

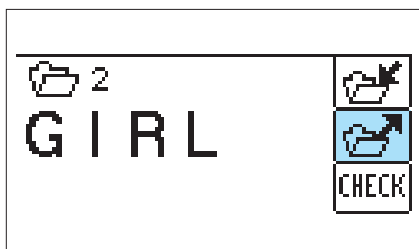

3. Press “  ” key.

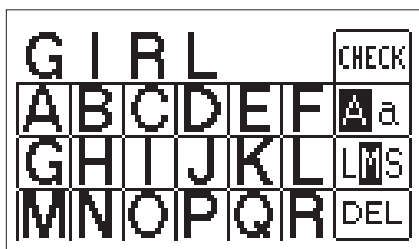

4. Pattern has been restored.

CLEANING

CAUTION

Disconnect the power cord from the wall socket before cleaning, otherwise injury or electric shocks may result.

Cleaning the screen

If the front panel is dirty, wipe it gently with a soft, dry cloth. Do not use any organic solvents or detergents.

Cleaning the sewing machine surface

If the surface of the sewing machine is dirty, lightly soak a cloth in neutral detergent, squeeze it out firmly and then wipe the surface. After cleaning it once in this way, wipe it again with a dry cloth.

Cleaning the shuttle

Sewing performance will be affected and bobbin thread detection will become unreliable if dust collects in the shuttle. It should be kept clean at all times.

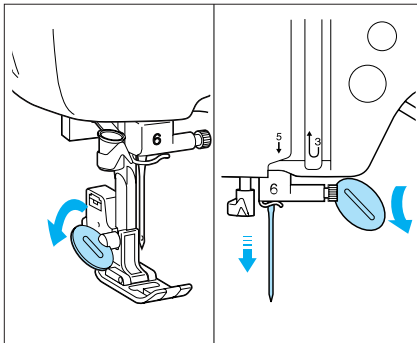

1. Turn off the power and remove the presser foot holder and the needle.

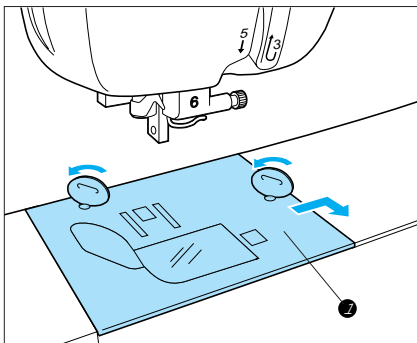

2. Loosen the screws.
3. Remove the needle plate.
 - 1 Needle plate

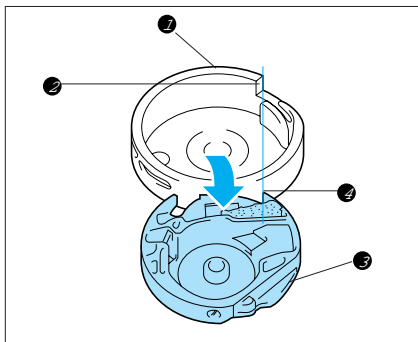

3. Turn the hand wheel towards you. Line up the shelf of race with the notch of shuttle and remove race.

- ① Shuttle
- ② Notch of shuttle
- ③ Race
- ④ Shelf of race

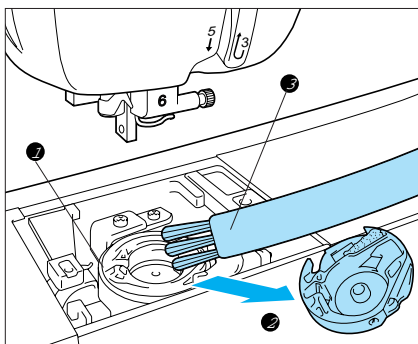

4. Remove accumulated lint and thread from the inner shuttle and race with a brush or a vacuum cleaner.

- ① Race
- ② Shuttle
- ③ Cleaning brush

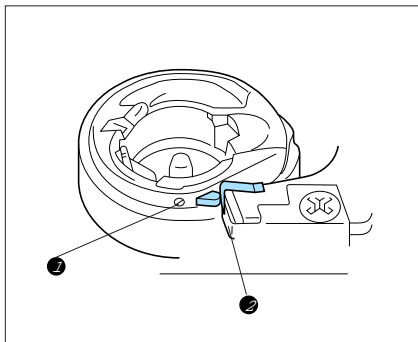

5. Remove the race and check that the notch of the shuttle is lined up in its original position by lining up the shuttle projection with the spring and insert the race.

- ① Projection
- ② Spring

6. Close needle plate and screw it shut.

CHANGING THE LIGHT BULB

CAUTION

The glass plate over the light bulb will be hot after running the machine. Please wait for it to cool off before changing the light bulbs so you don't burn yourself.

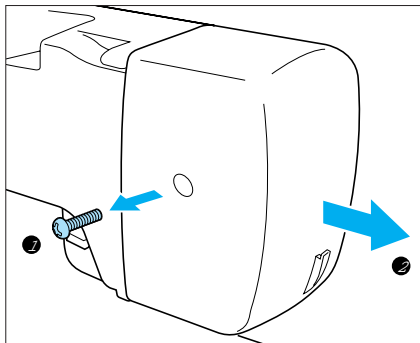

1. Turn the power off.
2. Loosen the screw on the reverse side of sewing head. Remove the end cap.

- ① Screw
- ② End cap

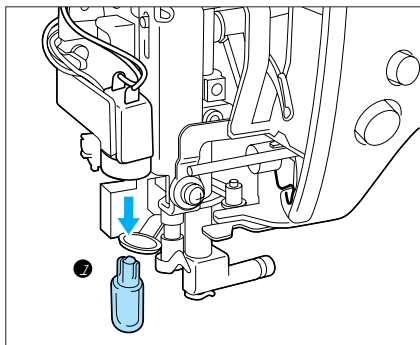

3. Replace the snap in the light bulb with a new one.

- ① Light bulb

* Light bulbs are available through your dealer. (8V, 2.4 W/ Parts code X50228001)

CAUTION

Do not use Brother 12V 5W light bulbs designed for use with this machine (part# XA2037001). Do not use other bulbs. Bulbs can be purchased at a Brother dealer near you.

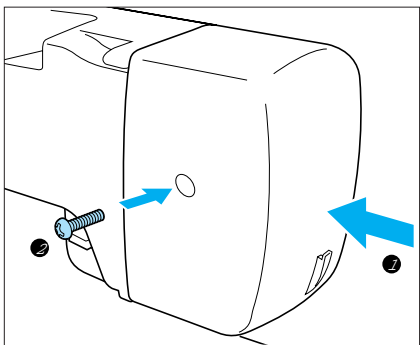

4. Set the end cap.
5. Tighten the screw.

- ① End cap
- ② Screw

TROUBLESHOOTING

BEFORE TAKING YOUR MACHINE IN FOR SERVICE

Basic sewing machine maintenance

Before calling for service, check the following items. If the problem still persists, contact the place of purchase or your nearest Brother dealer.

• Trouble with threads and stitches

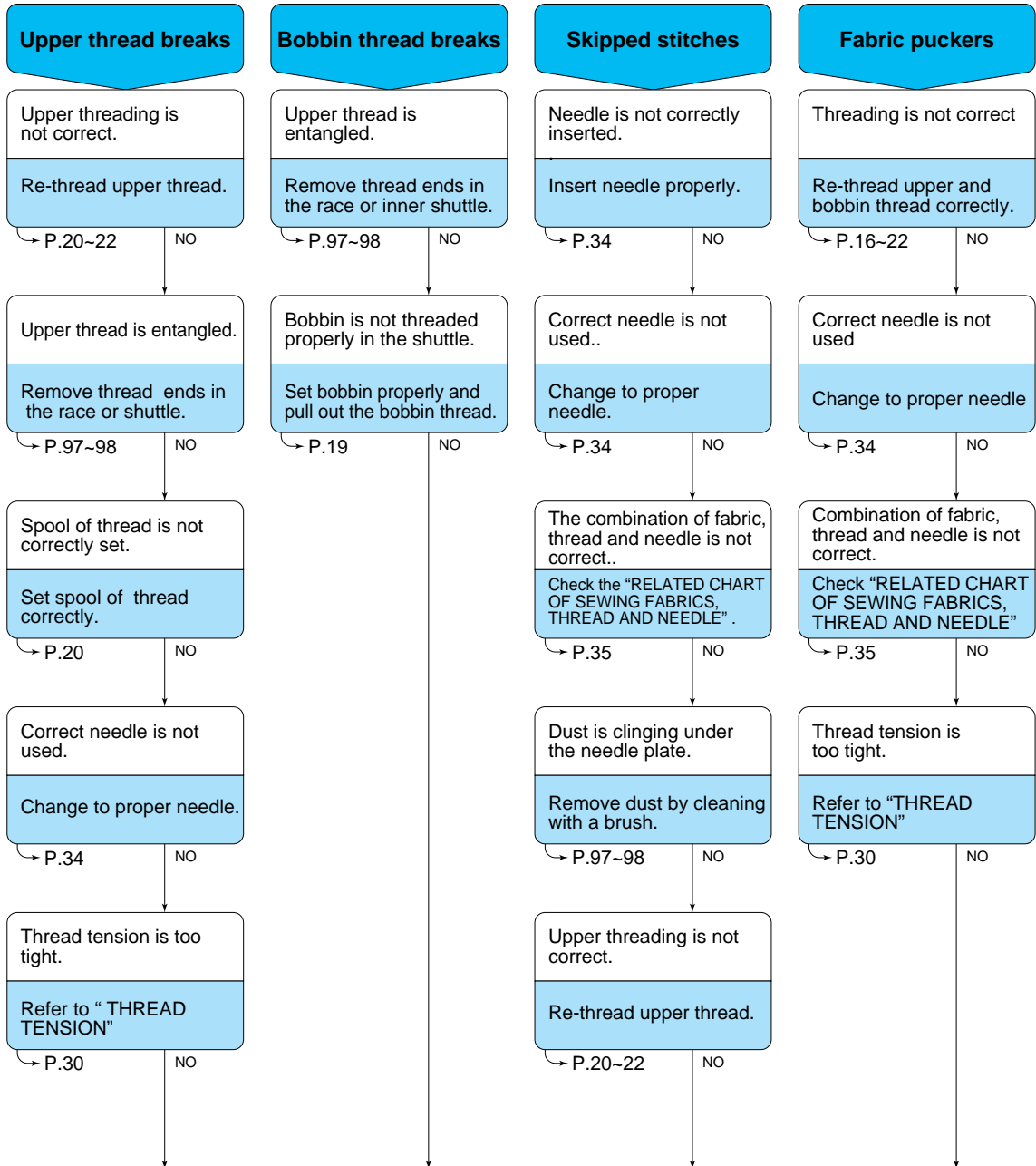

If you have gone through the troubleshooting tips and are still unable to find the source of the problem, please take your machine back to the place of purchase or your nearest Brother dealer for repairs.

FINDING THE SOURCE OF THE PROBLEM

• Trouble with threads and stitches

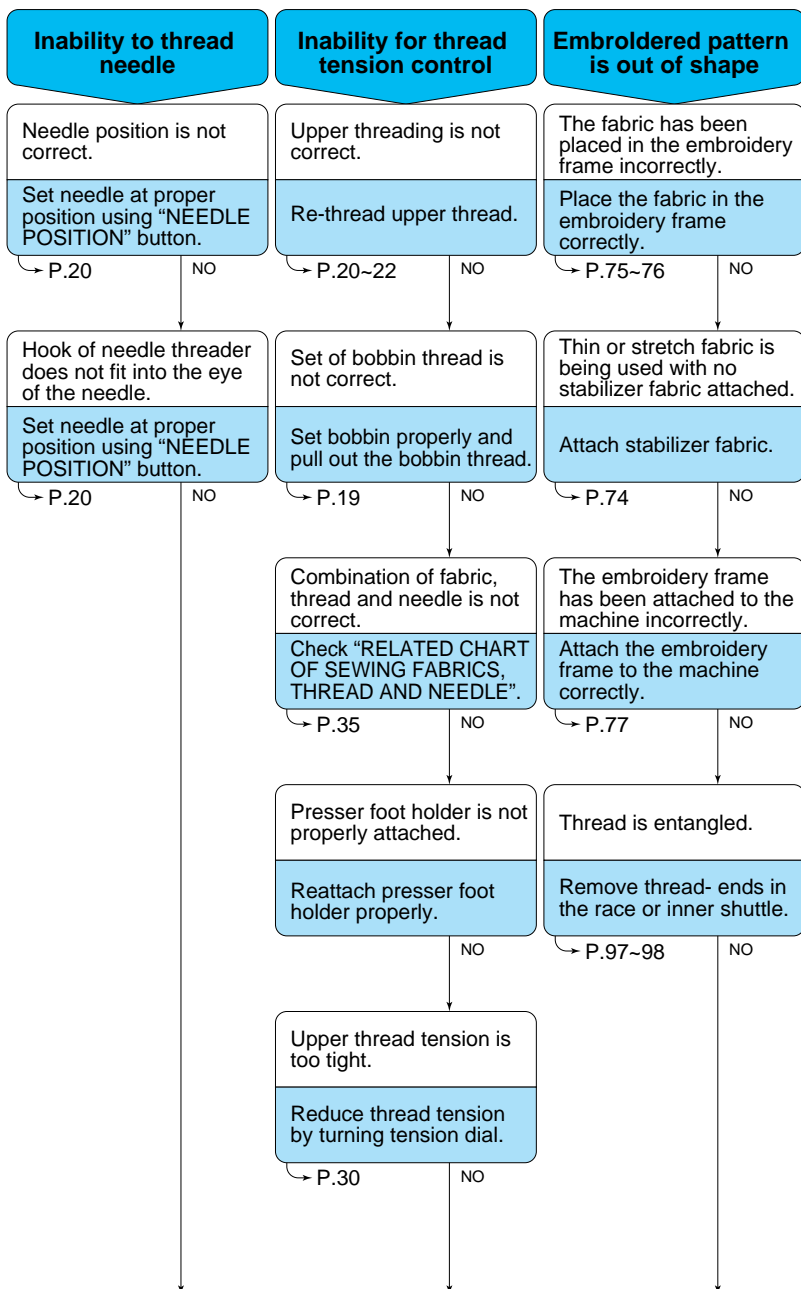

• Mechanical trouble

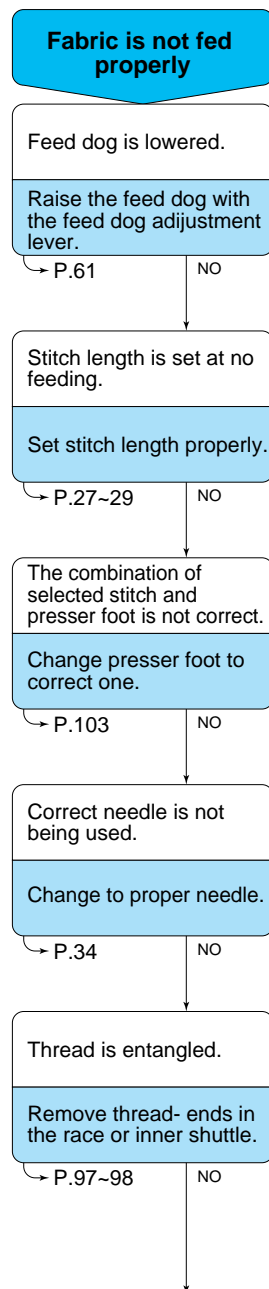

If you have gone through the troubleshooting tips and are still unable to find the source of the problem, please take your machine back to the place of purchase or your nearest Brother dealer for repairs.

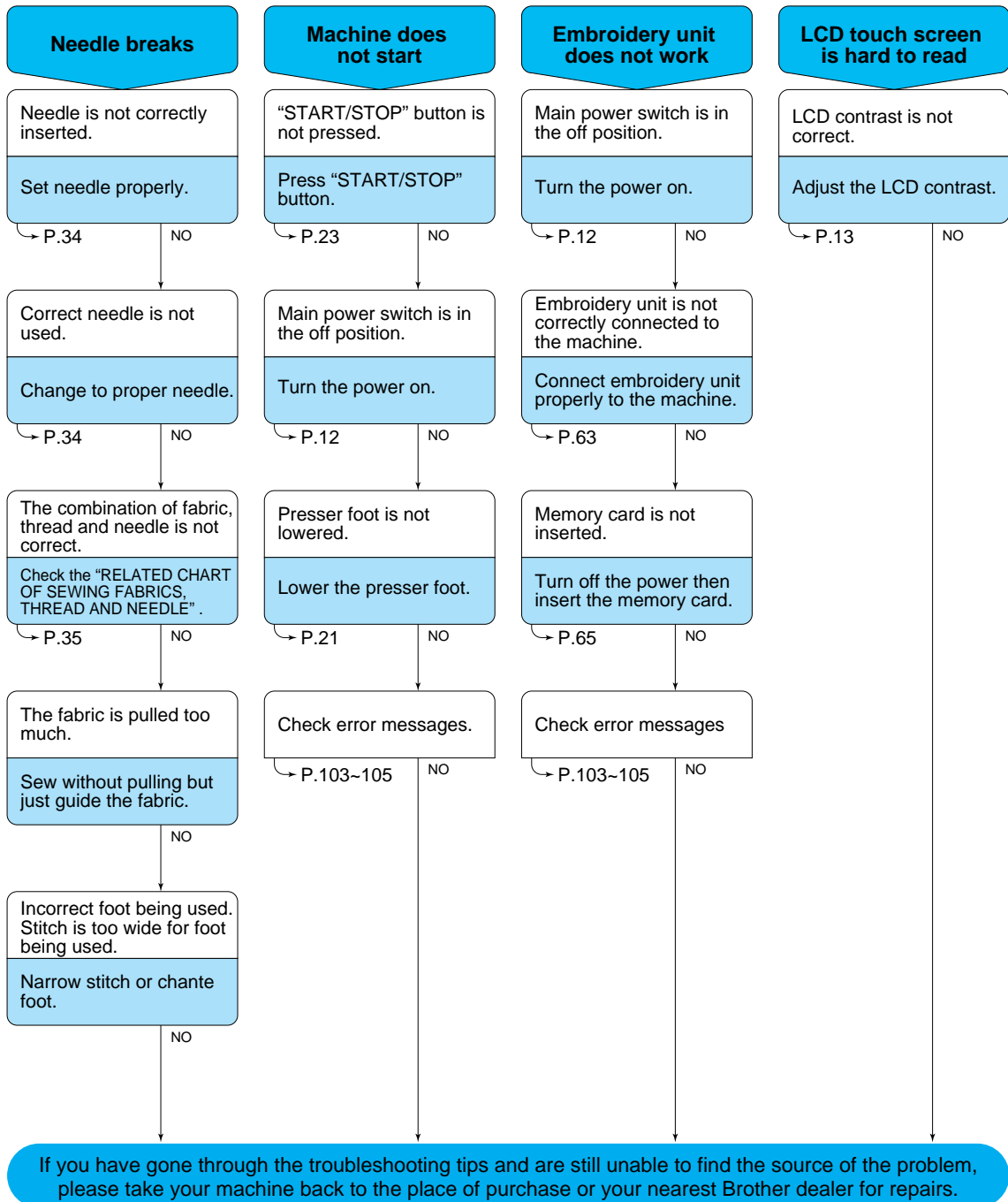
**Note**

- * This machine comes equipped with an upper thread sensor to prevent the machine from turning on if not properly threaded. If the machine doesn't start, check to see if the machine is threaded properly before worrying that something might be wrong.
- * If the power shuts off by itself while sewing:
Turn sewing machine off and unplug it.
Start the sewing machine again according to directions.

ERROR MESSAGES

Warning messages

A warning buzzer will sound and error message flash on your screen if the “START/STOP” or “REVERSE STITCH” button are pressed when the machine is not properly set up, or operated incorrectly. Please read the error message and follow instructions carefully. The following is a list of the machine's error messages and what each means. Please use this list for reference. (The error message will disappear from your screen once the problem is corrected.)

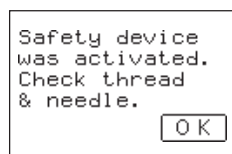

Make sure the thread is not tangled around the needle and that the needle is not bent.

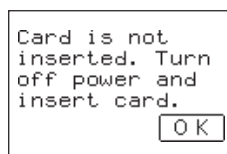

This message is displayed if the “” key is touched while there is no memory card inserted into the slot.

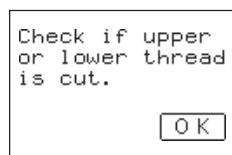

This message is displayed when the machine finds that the upper thread is cut. If thread breaks, rethread the machine.

* This message may also be displayed when upper thread tension is set extremely low.

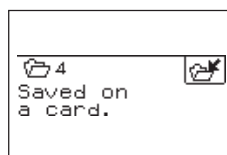

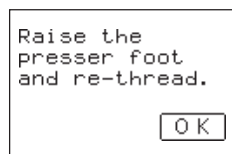

This message is displayed when trying to retrieve a pattern from a memory card and that memory card is not inserted.

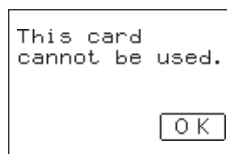

This message is displayed during embroidery mode if you push the “START/STOP” button without first lifting presser foot when changing threads.

If you are not changing threads, just raise and lower the presser foot to begin sewing again.



This message is displayed when the “” key is touched while a memory card that cannot be read by this machine is inserted.

The Following Memory Cards Are Not Compatible With This Sewing Machine

- * Quilt work (No.22)
- * White Embroidery (No.23)
- * Cards that are especially designed for use with other machines.

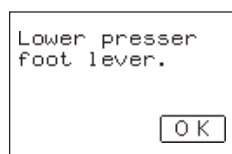

This message is displayed when the “START/STOP” or “REVERSE STITCH” button is pressed while the presser foot or embroidery foot is raised.

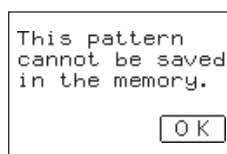

This message appears when you attempt to save a pattern that cannot be saved.

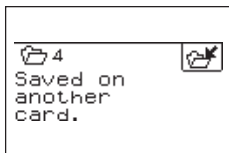

This message will appear when attempting to restore a memory card pattern that has been saved to a different memory card than the one inserted in the machine.

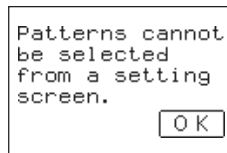

This message will appear if you attempt to select a pattern while you are still in mode.

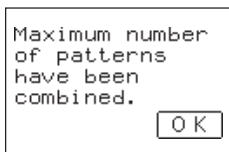

This message will appear if you attempt to combine over 36 characters in a single pattern.

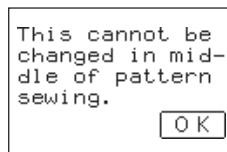

This message is displayed when the " " key is touched during embroidering or if the machine is stopped between color changes.

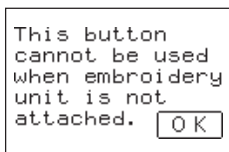

This message will appear if you press " " key in the utility stitch mode.

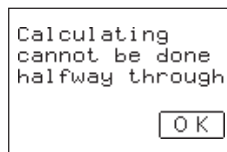

This message will appear if you press " " key while the machine is stitching.

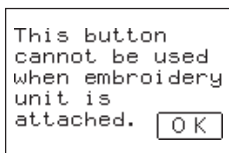

This message will appear if you attempt to use the foot controller or press "REVERSE STITCH" button during embroidery mode.

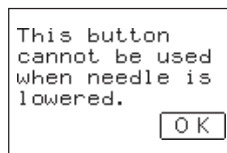

This message is displayed when a key on the screen is touched while the needle is down.

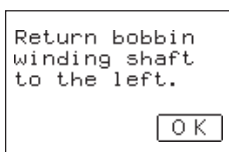

This message is displayed when the "NEEDLE POSITION" or "REVERSE STITCH" button is pressed while the bobbin winding shaft is pushed to the right.

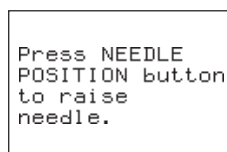

This message is displayed when the embroidery unit is attached while the needle is lowered.

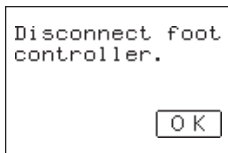

This message will appear if you press the “START/STOP” button while the foot controller is attached.

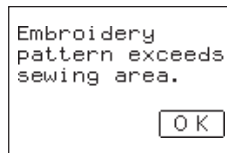

This message will appear during embroidery mode if you have combined a group of characters together that extend beyond the boundary of the embroidery hoop.

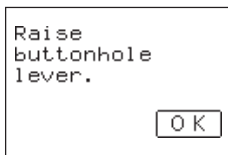

This message is displayed if a non-buttonhole pattern is selected and the “START/STOP” button or “REVERSE STITCH” button is pressed while the buttonhole lever is lowered.

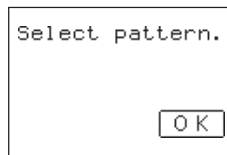

This message is displayed when “START/STOP” button or “REVERSE STITCH” button are pressed, while no pattern has been selected.

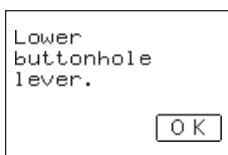

This message is displayed if a buttonhole pattern is selected and the “START/STOP” button or “REVERSE STITCH” button is pressed while the buttonhole lever is raised.

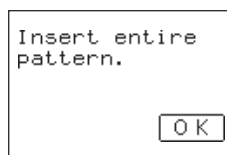

This message is displayed if the frame pattern for embroidering has not been completely input, and when the “START/STOP” button is pressed when in editing mode.



This message will appear if you press “” key to restore a pattern that has not been saved to memory.

Instruction messages

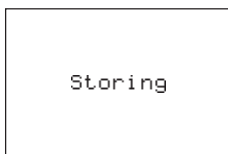

This message is displayed while a pattern is being saved into memory.

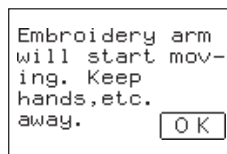

This message is displayed while the embroidery unit is initializing.

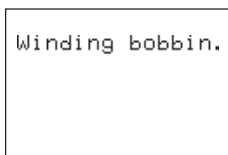

This message is displayed during bobbin winding.

Alarms

Proper operation: One beep
Incorrect operation: Two or four beeps

SEWING CHART

NAME OF PATTERN	PATTERN	TYPE OF PRESSER FOOT	USE	REINFORCEMENT STITCH KEY	STITCH WIDTH BY STITCH ADJUSTING KEY	STITCH LENGTH BY STITCH ADJUSTING KEY	NAME OF PATTERN	PATTERN	TYPE OF PRESSER FOOT	USE	REINFORCEMENT STITCH KEY	STITCH WIDTH BY STITCH ADJUSTING KEY	STITCH LENGTH BY STITCH ADJUSTING KEY
STRAIGHT			General sewing, gather, Pintuck, etc.	R	☆	☆	FAGOTING			Smocking, decorative stitching	△	☆	☆
				DECORATIVE FAGOTING		Fagoting, decorative stitching	△	☆		☆			
TRIPLE STITCH			General sewing for reinforcement	△	☆	☆	TRIPLE ZIGZAG			Decorative stitching	△	☆	☆
STRETCH STITCH			Straight stitching (attaching sleeves, reinforcing, sewing stretch fabrics)	△	☆	☆	SCALLOP			Decorating collar of blouse, edge of handkerchief	△	☆	☆
ZIGZAG			Overcasting, Patchwork	R	☆	☆	DECORATIVE			Decorative stitching	△	☆	☆
ELASTIC ZIGZAG STITCH			Overcasting (medium and stretch fabrics) Tape attaching, darning	△	☆	☆		SMOCKING			Decorative stitching	△	☆
OVERCASTING STITCH				Reinforcing of thin and medium fabric	△	☆	☆		DECORATIVE			Smocking, decorative stitching	△
			Reinforcing of thick fabric	△	☆	☆		Decorative stitching		△	☆	☆	
BLIND HEM STITCH			Reinforcement of skirts	△	☆	☆	DECORATIVE			Decorative stitching	△	☆	☆
			Reinforcement of skirts with stretch fabric	△	☆	☆				Decorative stitching	△	☆	☆
BUTTON-HOLE STITCH			Buttonholes for blouses and shirts	—	☆	☆	APPLIQUE			APPLIQUE	△	☆	☆
			Buttonholes for pajamas and shirts	—	☆	☆	DECORATIVE STITCHING			Decorative stitching of thin to medium stretch fabric	△	☆	☆
			Buttonholes for stretch fabric	—	☆	☆				Fagoting, decorative stitching	△	☆	☆
BAR TACK			Reinforcement at opening of pocket, etc.	—	☆	☆	DECORATIVE STITCHING			Decorative stitching	△	☆	☆
APPLIQUE			Appliques	△	☆	☆				Decorative stitching	△	☆	☆
SCALLOP			Decorating collar of blouse, edge of handkerchief	△	☆	☆				Decorative stitching	△	☆	☆

R Reverse sewing while the "REVERSE STITCH" button is pressed.

△ When the "REVERSE STITCH" button is pressed, the machine will sew three reinforcement stitches and stop.

☆ Adjustable

— Non-adjustable

PATTERNS (PROGRAMMED IN MACHINE)

Utility stitches

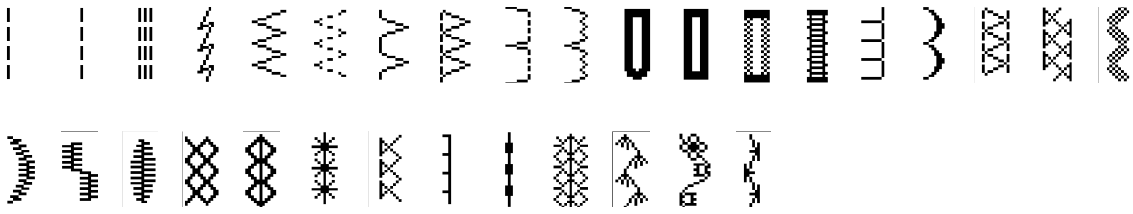

Character embroidering chart

Sizes: [L] 30mm (1-3/16"), [M] 15mm (9/16"), [S] 7.5mm (1/4"),

Sizes: [L] 30mm (1-3/16"), [M] 15mm (9/16"), [S] 10mm (0-3/8"),

ABCDEFGHIJKLMNOPS
 TUVWXYZ abcdefghijklm
 nopqrstuvwxyz
 ÄÅ Æ Ñ Ö Ø Ç Ü ß ä å æ è é ê ñ ö ò ø ÷ ü ù
 0123456789 & ? ! . - _ () ' , /

ABCDEFGHIJKLMNOPS
 TUVWXYZ abcdefghijklm
 nopqrstuvwxyz
 ÄÅ Æ Ñ Ö Ø Ç Ü ß ä å æ è é ê ñ ö ò ø ÷ ü ù
 0123456789 & ? ! . - _ () ' , /

Sizes: [L] 30mm (1-3/16"), [M] 15mm (9/16"), [S] 9mm (0-3/8"),



Frame pattern embroidering chart

Sizes can be enlarged or reduced.

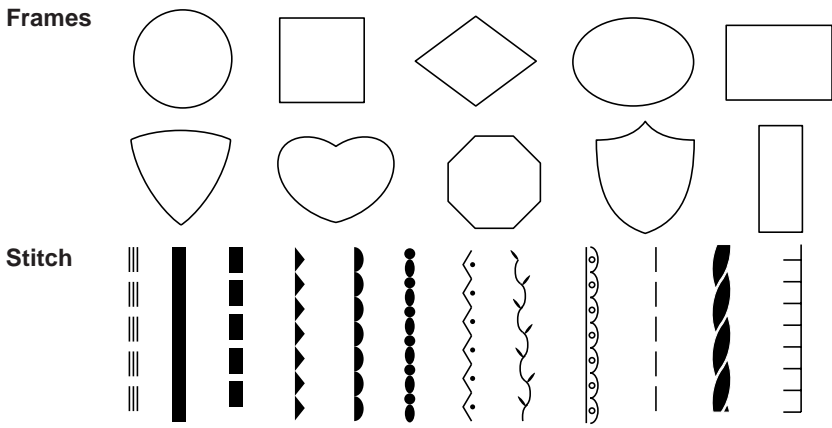

- Contents
- Setting Up
- Basic Sewing Machine Operation
- Utility Stitches
- Embroidering
- Maintenance
- Troubleshooting
- Error Messages
- Sewing Chart
- Patterns (Programmed In Machine)
- Patterns (Memory Card)

PATTERNS (MEMORY CARD)

ONE POINT MARK EMBROIDERY PATTERN

<Embroidering times: 2 - 31 min. (It does not include the time needed to change colors.)>

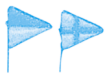

1 019
2 800
3 900



1 323
2 085
3 001
4 058



1 086
2 058
3 707



1 070
2 085
3 086
4 323



1 513
2 001
3 208
4 058



1 001
2 800
3 515
4 058
5 900



1 085
2 323
3 058



1 086
2 205
3 534
4 019



1 513
2 030
3 058



1 900



1 339
2 058
3 843
4 900



1 405
2 900
3 005
4 704



1 405
2 507
3 800
4 205



1 843
2 900
3 019



1 001
2 900



1 405
2 001
3 800
4 900
5 001
6 307
7 405
8 900
9 307
10 800
11 900



1 513
2 030
3 205
4 339
5 900



1 513
2 507



1 005
2 707



1 001
2 900



1 086



1 614



1 513
2 328
3 515
4 085
5 086
6 079
7 515



1 155
2 463



1 463
2 124



1 512
2 370



1 152
2 003



1 155
2 483



1 463
2 155



1 005
2 149



1 155
2 463



1 124
2 003



1 158
2 473



1 463
2 005
3 158



1 473
2 224
3 155



1 003
2 370
3 604
4 331
5 463



1 354
2 444
3 370
4 003
5 122
6 331



1 331
2 003
3 463



1 003
2 370



1 133
2 370



1 624



1 444
2 133
3 370



1 444
2 370
3 003



1 485
2 158



Patterns which are stored in the machine or memory cards are for home use only. These patterns are not to be used for any activity other than home use.